

User Manual

用户手册

EC Series Cabinet Air Conditioner

EC 系列机柜空调器

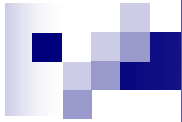

Shenzhen Envicool Technology Co., Ltd.

深圳市英维克科技股份有限公司

CONTENTS

1 BRIEF INTRODUCTION.....	1
1.1 FOREWORD.....	1
1.2 AIR CONDITIONER DESCRIPTION.....	1
1.3 STANDARDS.....	2
2 INSTALLATION AND OPERATION.....	3
2.1 REMOVING PACKAGE AND CHECKING.....	3
2.2 PREPARATION BEFORE THE INSTALLATION.....	3
2.3 MECHANICAL INSTALLATION OF THE AIR CONDITIONER.....	3
2.4 ELECTRICAL INSTALLATION.....	4
2.5 INSTALLATION CHECK LIST.....	6
2.6 POWER-ON STEPS.....	6
3 SYSTEM FUNCTION INTRODUCTION.....	7
3.1 FUNCTION.....	7
3.2 COOLING AND HEATING.....	7
3.3 THE CONTROL OF EXTERNAL FAN (OPTION).....	8
3.4 PROCESSING OF THE DOOR MAGNETIC SWITCH SIGNAL (OPTION).....	8
3.5 SELF TESTING.....	8
3.6 ALARM.....	9
3.7 MONITORING.....	9
3.8 UNIT MENU STRUCTURE.....	9
4 DAILY MAINTENANCE.....	12
5 FAULTS AND RECOVERY MEASURES.....	13
5.1 FAN FAULTS.....	13
5.2 COOLING SYSTEM FAILURE.....	13

目 录

1 简介	15
1.1 前言.....	15
1.2 空调器描述.....	15
1.3 符合标准.....	16
2 安装和操作	16
2.1 拆除包装和检验.....	16
2.2 安装前准备.....	16
2.3 空调器机械安装.....	17
2.4 电气安装.....	17
2.5 安装查检表.....	19
2.6 开机步骤.....	19
3 系统功能介绍	20
3.1 功能.....	20
3.2 制冷与加热.....	20
3.3 外部风扇联动功能（选配）.....	21
3.4 门禁功能（选配）.....	21
3.5 自测.....	21
3.6 告警信息.....	21
3.7 监控.....	22
3.8 机组菜单结构.....	22
4 日常维护	23
5 故障及恢复措施	24
5.1 风机故障及恢复措施.....	24
5.2 制冷系统故障及恢复措施.....	24

1 Brief Introduction

1.1 Foreword

Note: All the operations of this product shall be performed by professional engineers and technicians.

This manual shall only be used as the guide for the installation and operation of the EC series outdoor cabinet air conditioner. It introduces the functions and daily maintenances of the unit.

1.2 Air conditioner description

The EC series outdoor cabinet air conditioner is a cooling product developed for cabinet. It is applicable for the scenarios where internal equipment of the cabinet emits a large quantity of heat and the internal equipment is sensitive for temperature and needs to be isolated from the outdoor environment completely. The unit has perfect functions, such as with external fan controlled functions and features high reliability and easy installation, so that it can work once the power supply is available and no complex adjustment is needed.

The internal cycle air path absorbs the hot air from the upside, and discharges the cold air from the downside of the air conditioner. The external cycle air path absorbs the external cold air from the downside, and discharges the hot air from the upside after heat exchange, as shown in Fig.1.1.

Note: It is prohibited to put the air conditioner upside down during transportation, storage and use.

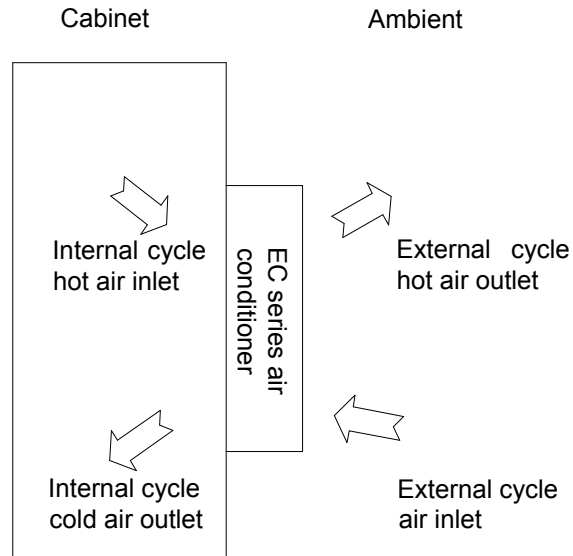

Fig.1.1 Functional diagram

Application scope:

Grid application scope:

- 1) AC: 220VAC \pm 15% 50Hz
- 2) AC: 220VAC \pm 15% 50/60Hz(Dual live line support 110 VAC;60Hz)

Note: the actual use power supply will be subject to nameplate instructions.

External cycle temperature: -40 °C ~ 55 °C

1.3 Standards

Table 1.1 Applicable standards of products

Standard	Description
GB/T 17626.7-1998	EMC
GB4706.1	Safety of household appliances or similar electric appliance
GB4798.1	Environmental conditions existing in the application of electric and electronic product – Storage
GB4798.2	Environmental conditions existing in the application of electric and electronic product – Transportation
GB4798.3	Environmental conditions existing in the application of electric and electronic product – Use
CE	Third-party certification

2 Installation and Operation

2.1 Removing package and checking

The standard package of this product is carton. To remove the package, remove the external straps first, and then open the top cover and pull out the carton. Please check the attachment list and accessory bags in the carton.

Note:

1. When the package is removed, make sure that the air conditioner is placed vertically. It can't be placed horizontally or upside down.
2. When the external package is removed, please check carefully whether the appearance of the air conditioner is damaged or whether there is any oil stain. If any damage is found, please report this with the barcode number on the package to the retailer or Envicool.
3. If there is no need to install the product immediately or it needs to be transported to other place, please repack the air conditioner after the checking.
4. To protect the environment, it is recommended to recycle the packing cartons.

2.2 Preparation before the installation

Please pay attention to the following points before the installation:

- The placement of the equipment inside the cabinet should be proper. For example, any obstruction to the internal cycle air inlet and outlet of the air conditioner should be avoided.
- The layout of drainage channels should be fully considered.

2.3 Mechanical installation of the air conditioner

The mechanical installation of the air conditioner includes:

- Sticking the sealing tapes on the cabinet and the air conditioner
- Fixing the air conditioner on the cabinet

Installation tool: Phillips screwdriver.

Please install the unit strictly in accordance with the following steps:

1. Check the accessories (electrical part: air conditioner power cables , the communication & alarm output cables; other materials: screws), and prepare the installation tools.
2. Seal the installation surface of the cooling units and the cabinet with sealing tapes.
3. Fix the air conditioner on the installation surface of the cabinet firmly with screws.

2.4 Electrical installation

The electrical installation of the air conditioner includes:

- Connecting the power cables
- Connecting the communication & alarm output cables

Note: All the electrical connections should comply with the standards of the national and local electrical codes. Please disconnect all the power supplies for the air conditioner before the installation.

Please select proper wire diameter and circuit protection device according to the air conditioner nameplate and technical parameters.

Please perform the electrical connection in accordance with the following steps:

1. Make sure that the air conditioner power is disconnected.
2. Connect the power cable to the input terminal according to the schematic diagram for power terminal.
3. Connect the power input terminal to the attaching plug of the unit reliably and tighten the fixing screws.
4. Connect the other end of the power cable to the power supply according to the definition.
5. Connect the communication & alarm output cable to the input terminal according to the definition.
6. Check whether any short circuit or open circuit exists on the AC power supply cables with multimeter.
7. Check whether any short circuit or open circuit exists on the communication & alarm output cable multimeter.

➤ **Connecting interface :**

Type	Pin	definition
Power input	L1/L	L:220VAC power input cable L; L1:110VAC power input cable L
	L2/N	N:220VAC power input cable N; L2:110VAC power input cable L
	PE	Grounding wire of the air conditioner
Alarm output	NC	The first public alarm dry nod (NC)
	COM	The first public alarm dry nod (COM)
	NO	The first public alarm dry nod (NO) (Option)
	1	The second public alarm dry nod (COM) (Option)
	2	The second public alarm dry nod (NO) (Option)
Signal input	3	N/A
	4	Hydrogen discharge / emergency fan dry contact (FG) (Option)
	5	Hydrogen discharge / emergency fan dry contact (NO) (Option)
	6	Hydrogen discharge / emergency fan dry contact (COM) (Option)
	7	Door open alarm input (Option)
	8	
communication ports	+	RS485 communication ports (+) (Option)
	-	RS485 communication ports (-) (Option)

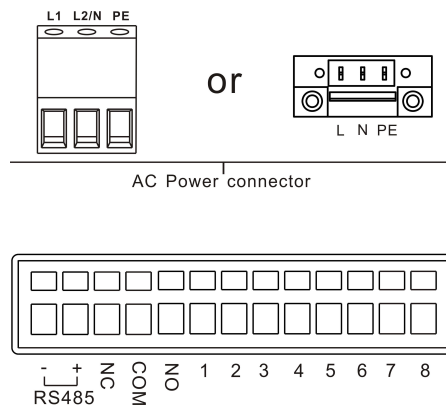

Fig.2.1 connecting interface (The power input port identification will be subject to nameplate instructions)

The alarm dry contact COM、NC normally close output. When faults occur, the dry contact will open.

Notice: Contact capacity: max load 8A@230VAC(2A@48VDC).(option)

➤ Hydrogen discharge / emergency fan(AC input) connecting interface diagram;

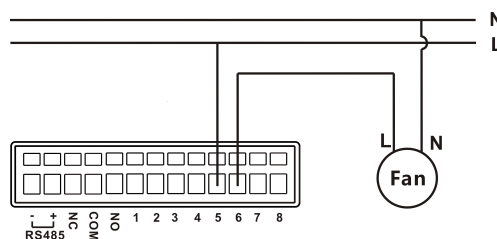

Fig.2.2 AC input connecting interface diagram

- Hydrogen discharge / emergency fan(DC input) connecting interface diagram;

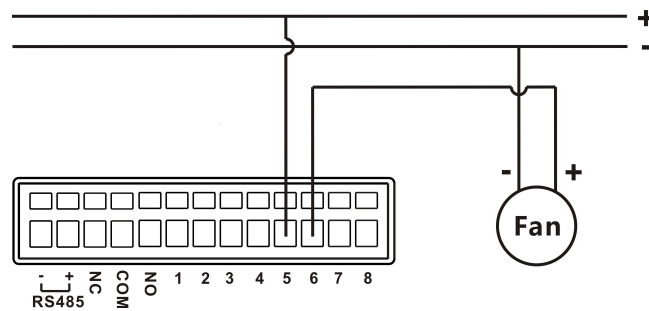

Fig.2.3 DC input connecting interface diagram

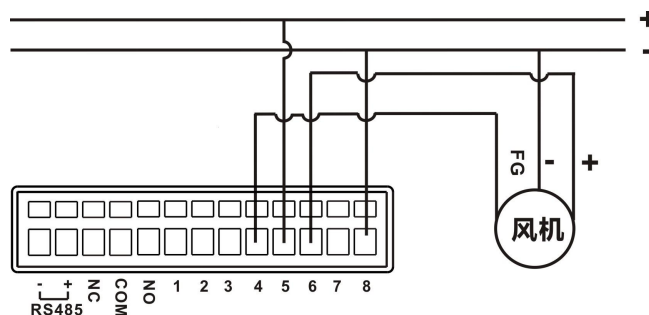

Fig.2.4 DC input connecting interface diagram (FG:optional)

2.5 Installation check list

Please check the following check list when the electrical installation and the air conditioner installation are completed.

1. There is no obvious obstacle near the internal cycle air inlet and outlet of the air conditioner.
2. The air conditioner is installed vertically and all the installation screws are tightened.
3. The AC input cables have been connected reliably.
4. The AC input voltage should comply with the standard in section 1.2.
5. The fan can turn freely without abnormal noises.

2.6 Power-on steps

Close the AC input power switch, Waited 30s ,The internal cycle fan of the air conditioner will be started. If the internal cycle temperature meets the running condition, the cooling system will be started.

3 System function introduction

3.1 Function

The air conditioner's running is controlled automatically according to the cabinet internal temperature. The controller controls the compressor or the fan's operation by comparing and judging the cabinet return air's temperature detected by the internal cycle temperature sensor with the setting point.

3.2 Cooling and Heating

Cooling startup point = cooling stop point + cooling sensitivity. When the cabinet internal temperature exceeds the cooling startup point, the cooling will be started; when the cabinet internal temperature is lower than the cooling stop point, the cooling stops.

The heating function works when the enclosure is below the heating start point, when the enclosure temperature is beyond the heater on point, the air conditioner's heater stops. The heater off point = heater on point + heater sensitivity. The set-point is listed in following forms.

Table 3.1 User parameter setting point (Equipment cabinet Applications)

Parameter	Default value	Setting range	Unit	Setting point description
CoolSP	25	[15~55]	°C	Point when cooling stops
CoolΔT	10	[1~10]	°C	Temperature control sensitivity
INHT	55	[30~ 70]	°C	Internal high Temp. alarm point
HeatSP	15	[5~ 25]	°C	Point When heating stops
HeatΔT	10	[1 ~ 10]	°C	Temperature control sensitivity

Table 3.2 User parameter setting point (battery cabinet Applications)

Parameter	Default value	Setting range	Unit	Setting point description
CoolSP	23	[15~55]	°C	Point when cooling stops
CoolΔT	3	[1~10]	°C	Temperature control sensitivity
INHT	40	[30~ 70]	°C	Internal high Temp. alarm point
HeatSP	15	[5~ 25]	°C	Point When heating stops
HeatΔT	5	[1 ~ 10]	°C	Temperature control sensitivity

Notice:

- 1、 To ensure the reliable operation and maximum energy efficiency of the unit, please do not change the temperature setting point unless necessary.
- 2、 Cooling parameter should set Factory Defaults for other different units.
- 3、 The heating function is optional

3.3 The control of external fan (Option)

According to the requirement for the environment inside the cabinet, the external fan (Hydrogen discharge / emergency fan) realizes automatic cycle hydrogen discharging and forced ventilation.

Discharge hydrogen at regular times (Option): The interval time of each automatic cycle hydrogen discharging is 24 hours(Can be set) and the discharging time is 5 minutes.

Forced ventilation (Option) : when the compressor does not have cooling capacity or the temperature inside the cabinet is higher than “INHT” point , and the temperature inside the cabinet is 4°C higher than that outside the cabinet, start the hydrogen discharging fan.

3.4 Processing of the door magnetic switch signal (option)

After judging whether the cabinet door is opening or not by the sign sent by the door magnetic switch ,the air conditioner will alarm and stop(stopping is an option).

3.5 Self testing

The unit provides the self testing function for the onsite test. The self testing procedures are as below:

1. Select the “Diagnosis” function in the “Set Up” menu, the unit will start the self testing procedure automatically.
2. The indoor fans run for 30 seconds.
3. The compressor and the outdoor fans run for 3 minutes.
4. The compressor and external fan stops and heater works for 2 minutes.
5. If the Control of external fan is optional ,the external fan will run for two minutes (if not,there will be no this item).
6. The unit works according to the normal logic.

3.6 Alarm

The cabinet air conditioner provides the following alarm information. Please refer to table 3.1 and table 3.2 for the setting point.

Table 3.3 Alarm parameter and the setting point

Parameter	Alarm conditions	Uploading or NO
Cabinet internal high Temp. alarm	The cabinet internal temperature exceeds "INHT"	YES
Coil freeze protection	Coil Temp. is lower than 0℃	YES
Frequent high system pressure alarm	High pressure switch act times.	YES
Controller power failure	No power input for controller.	YES
Temperature sensor inside the cabinet failures	There is short or open circuit on the sensor cable.	NO

3.7 Monitoring

The air conditioner communicates with the upper monitor through the RS485 communication interface. Or users can check the air conditioner's running state by viewing the display screen directly and change its running parameters.

3.8 Unit menu structure

The unit controller adopts the 96x32 LCD, which contains 7 buttons for the setting. The operation interface is as shown in the following figure.

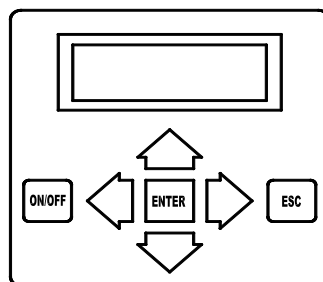

Controller operation interface

ON/OFF: ON/OFF button, (long press this button, about 5s) this can be used to turn on/off the unit.

↑: Up button, which is used to select the previous record/menu or increase the setting value (password only).

↓: Down button, which is used to select the next record/menu or decrease the setting value (password only).

←: Left button, which is used to increase the setting value during the parameter setting or select the previous bit of the data during the password setting.

→: Right button, which is used to decrease the setting value during the parameter setting or select the next bit of the data during the password setting.

ENTER: ENTER button, which is used to confirm the entry.

ESC: Quit button, which is used to return to the previous page menu.

If there is no keyboard operation for consecutively 60s under any interface after startup, it will automatically return to the normal display interface.

When any button is pressed after the system is powered up, the backlight will turn on. If there is no keyboard operation for consecutively 60s, the backlight will be off.

The factory default operation password of the unit is "0001". To change it, you need to press ENTER on the normal display interface to enter the password input interface, press the LEFT button or RIGHT button to select the bits for change, and press the UP/DOWN button to change the relevant digits, and finally press ENTER button to confirm the change. If the password is incorrect, the interface will display the error message, and the unit setting cannot be changed. If the password is correct, you can enter the main menu and edit the unit setting.

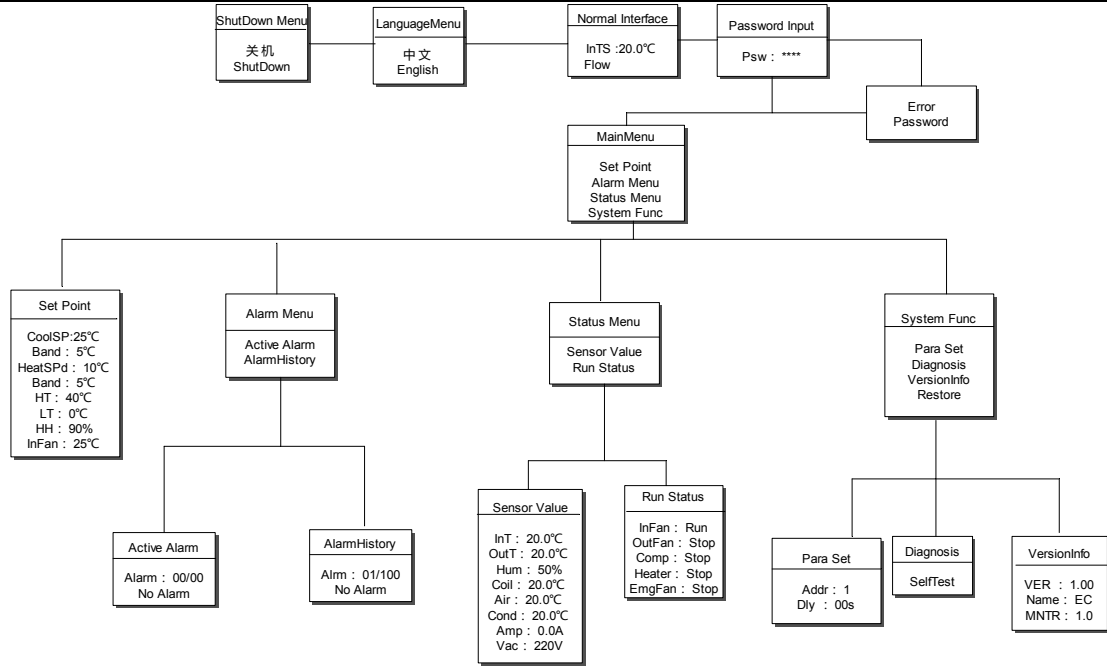

Note: The above diagram is unit menu structure, not the factory setting.

4 Daily maintenance

To ensure the normal operation of the air conditioner, please perform regular maintenances for it by referring to Table 4.1.

Warning: All the maintenances should be performed by qualified professionals. Please disconnect the power and communication & alarm output cables of the air conditioner before any maintenance and do not reconnect them until the maintenance is completed.

Table 4.1 Daily maintenance table

Check item	Step description	Maintenance cycle
Wiring	Visually check if the wiring is loose	12 months
Fan abnormalities	Turn the fan to check if it is smooth and if there is any abnormal noise	12 months
Drainage pipe	Visually check if the drainage mouth is blocked	6 months
Condenser	Check the cleanness of the condenser and clean it with compressed air	6 months

5 Faults and recovery measures

5.1 Fan faults

Table 5.1 Fan faults and recovery measures

Symptom	Possible cause	Check items or processing method
Internal cycling fan cannot run	Air conditioner is in the standby state	It is a normal case ,air conditioner will get into the automatic control logic after being power on and in the standby for 30s.
	The fan gets stuck	Check if there is any foreign object that blocks the fan.
	The terminal is loose	Check if the fan connecting terminal is loose
External cycling fan cannot run	the compressor is not started	The outside fan can run after the compressor starts.
	The fan gets stuck	Check if there is any foreign object that blocks the fan.
	The terminal is loose	Check if the fan connecting terminal is loose.
Fan makes abnormal noise	The bearing of fan wears	replace the fan.
	The blades of fan scratch other objects	Check whether there are any interferences between the cable and the blades of the fan.
The external hydrogen discharge fan does not work	Setting error or the operating condition has not been satisfied	Check if the operating condition is satisfied.
	Power cut-off	Check the external power supply.
	The fan cannot work	Replace the fan.
	The default is not opened	Make sure whether there is an external fan linkage function configuration.

5.2 Cooling system failure

Table 5.2 Cooling system faults and recovery measures

Symptom	Possible cause	Check items or processing method
The compressor cannot start	The power supply is not started (standby)	Check the main power switch, and check if the startup interface is displayed.
	Loose circuit connection	Tighten the circuit connectors.
	The compressor motor burns out	Check the motor and replace it if any defect is found.
The compressor cannot work	There is no cooling demand	Check the display of the temperature inside the cabinet and the compressor output status on the operation interface.

	Within shutdown delay	The compressor has the shortest shutdown time in normal state. If the temperature rises to the starting point during this period, the compressor still would not start until the time delay expires.
High discharge pressure	The condenser is clogged by dirt	Clean the condenser.
	The condenser fan does not work	Refer to table 5.1.
The evaporator freeze up	The internal circulation fan is not running	Refer to table 5.1.
	The capillary temperature sensor can not work	Check whether the connection is normal ,if not ,replace the capillary temperature sensor.

1 简介

1.1 前言

注意：任何针对本产品的操作必须由专业的工程技术人员进行。

本手册只能用于指导 EC 系列室外型机柜空调器的安装和操作。手册内容包含机组的功能描述和定期维护。

1.2 空调器描述

EC 系列室外型机柜用空调器产品是针对机柜等应用环境而开发的一款制冷产品。适用于机柜内部设备发热量较大，内部设备对于环境温度敏感，且内外需要完全隔离的应用场合。本产品功能齐备，有外部风机控制功能，可靠性高，安装简单便捷，通电后即可工作，无需复杂调试。

空调器内循环的风路从上部吸入热空气，冷空气从下部排出空调器。外部循环从下部吸入外界冷空气，经过热交换后热空气从上部排出空调器。见图 1.1

注意：空调在搬运、储存和运行过程中严禁倾倒。



图 1.1 功能示意图

适用范围：

电网适用范围：

1) 交流：220VAC±15% 50Hz

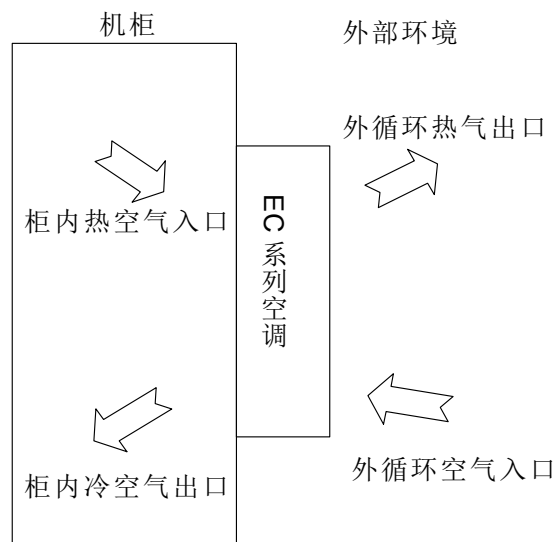
2) 交流: 220VAC \pm 15% 50/60Hz(支持 110 VAC 双火线输入;60Hz)

注: 实际使用电源制式以铭牌标称为准。

外循环温度: -40 $^{\circ}$ C ~ 55 $^{\circ}$ C

1.3 符合标准

表 1.1 产品适用的标准

标准	标准描述
GB/T 17626.7-1998	电磁兼容性
GB4706.1	家用和类似用途电器的安全
GB4798.1	电工电子产品应用环境条件-储存
GB4798.2	电工电子产品应用环境条件-运输
GB4798.3	电工电子产品应用环境条件-使用
CE	第三方认证

2 安装和操作

2.1 拆除包装和检验

本产品标准采用纸箱包装, 拆除包装时, 先将包装外部的打包带拆除, 打开纸箱上盖并将纸箱抽出。注意清点包装内的装箱清单和附件包。

注意:

1. 拆除包装后, 请确保空调竖立放置, 不能平放或者倒置。
2. 拆除外部的包装后, 请仔细检查空调器外观是否有损伤或者油污。如果发现了任何损伤, 请在一周内连同包装外的条形码编号报告销售商。
3. 如果产品不是立即安装或者需要转运到其它地区, 请在检查完后重新对空调器进行包装。
4. 为了保护环境, 我们建议对包装纸箱进行回收利用。

2.2 安装前准备

安装前注意:

- 机柜内部环境设备的摆放, 如与空调器内循环进出风口有阻隔, 尽量避免。

- 考虑好排水通道的布置。

2.3 空调器机械安装

空调器机械安装包括如下工作：

- 空调器贴密封海绵。
- 在机柜上固定空调器。

安装工具：十字螺丝刀。

安装时必须严格按照下述的步骤进行安装：

1. 清点附件（电气部分：空调电源线缆、告警输出线缆；其他材料：螺钉）并准备安装工具。
2. 用密封胶条对机组和机柜的安装面进行密封。
3. 用安装螺钉将空调可靠固定在机柜安装面上。

2.4 电气安装

空调器电气安装包括如下工作：

- 连接电源线
- 连接通信及告警输出线缆

注意：所有电气连接都必须符合国家和当地电气规范要求，安装前断开所有的空调电源。

根据空调铭牌和技术参数选择合适的线径以及电路保护装置。请根据铭牌的指示和机组上的说明进行线缆的连接。

按照以下步骤进行电气连接：

1. 确认空调电源断开。
2. 按照电源端子信号定义将电源线与输入端子连接。
3. 将输入端子可靠连接在机组的电源插头处，并将固定螺钉紧固。
4. 将电源线另一端按照定义接入到相应的配电空开上。
5. 将信号线缆按照定义接入到信号输入端子上。
6. 用万用表测试交流电源输入线缆是否有短路，断路的现象。
7. 用万用表测试通信及告警输出线缆是否有短路，断路现象。

➤ 端子接口：

类型	对应管脚	信号定义
电源	L1/L	L:220V火线; L1:110V火线
	L2/N	N:220V零线; L2:110V火线
	PE	空调电源地线
告警输出	NC	第 1 路公共告警继电器干接点输出 NC 触点
	COM	第 1 路公共告警继电器干接点输出 COM 触点
	NO	第 1 路公共告警继电器干接点输出 NO 触点 (选配)
	1	第 2 路公共告警继电器干接点输出 COM 触点 (选配)
	2	第 2 路公共告警继电器干接点输出 NO 触点 (选配)
信号输入	3	N/A
	4	排氢/应急风扇反馈输入 (选配)
	5	排氢/应急风扇控制继电器干接点输出NO (选配)
	6	排氢/应急风扇控制继电器干接点输出COM (选配)
	7	门禁告警输入 (选配)
	8	
通信	+	RS485 接口 D+ (上位机监控接口) (选配)
	-	RS485 接口 D- (上位机监控接口) (选配)



图 2.1 接口端子标识示意图 (电源输入口标识以具体机组丝印为准)

当公共告警干节点按 COM、NC 接线时，无告警输出时干节点为闭合状态，有告警输出时干节点为断开状态。

注意：排氢/应急风机干接点最大容量为：交流风机：8A/230V；直流风机：2A/48V。（选配）

➤ 交流排氢/应急风机输入端口接线示意图：

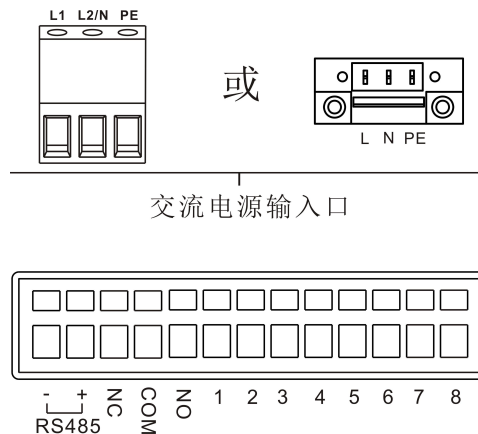

图 2.2 交流排氢/应急风机输入端口接线示意图

➤ 直流排氢/应急风机输入端口接线示意图：



图 2.3 直流排氢/应急机输入端口接线示意图

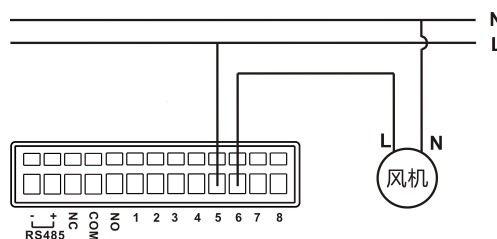

图 2.4 直流排氢/应急风机输入接口接线示意图（FG：选配）

2.5 安装查检表

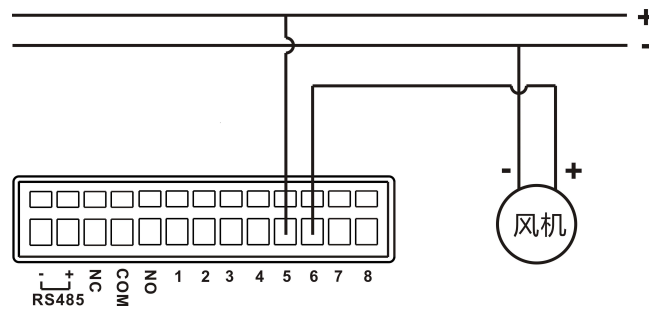
在电气和空调器安装完毕后，请核对下列查检表。

1. 空调器的内外循环的进/出风口附近无明显的阻挡物。
2. 空调器竖直安装，且所有安装螺钉已经紧固。
3. 交流输入电源线已经可靠接驳。
4. 交流输入电压符合 1.2 节中内容。
5. 风机可以自由顺畅转动，无异响。

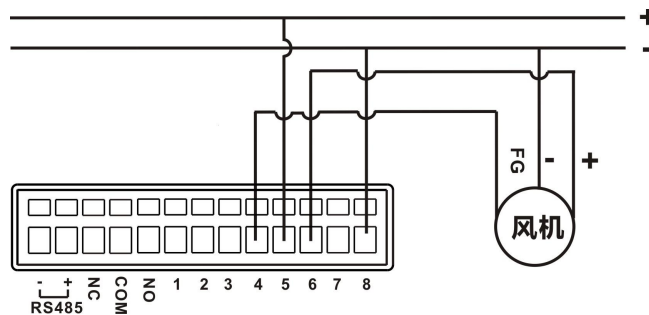
2.6 开机步骤

闭合交流输入电源空开，待机 30 秒后，此时空调器内循环风机运行。如果内循环温度达到运行的条件，制冷系统运行。

3 系统功能介绍

3.1 功能

空调器运行完全根据机柜内部的温度自动控制，控制器通过内循环温度传感器检测机柜回风温度，和设定点比较进行判断，控制压缩机或风机的工作。

3.2 制冷与加热

制冷开启点=制冷停止点+制冷灵敏度，当机柜内部温度超过制冷开启点，开始制冷运行，当柜内温度低于制冷停止点，制冷运行停止。

加热停止点=加热开启点 + 加热灵敏度，当机柜内部温度低于加热开启点，开始加热运行，当柜内温度高于加热停止点，加热运行停止。

表 3.1 设备仓专用空调用户参数设置点

参数	缺省值	设置范围	单位	设置点描述
制冷停止点	25	[15~55]	℃	制冷运行停止的温度点
制冷灵敏度	10	[1~10]	℃	温度控制的灵敏度
内高温	55	[30 ~70]	℃	柜内高温告警点
加热停止点	15	[5 ~25]	℃	加热运行停止的温度点
加热灵敏度	10	[1 ~10]	℃	温度控制的灵敏度

表 3.2 电池仓专用空调用户参数设置点

参数	缺省值	设置范围	单位	设置点描述
制冷停止点	23	[15~55]	℃	制冷运行停止的温度点
制冷灵敏度	3	[1~10]	℃	温度控制的灵敏度
内高温	40	[30 ~70]	℃	柜内高温告警点
加热停止点	15	[5 ~25]	℃	加热运行停止的温度点
加热灵敏度	5	[1 ~10]	℃	温度控制的灵敏度

注意：

- 1、为使机组运行可靠和发挥最大能效，不建议用户随意更改温度设定点。
- 2、个别不同的机型，制冷参数设定的缺省值以出厂默认值设定值为准。
- 3、加热属于选配功能。

3.3 外部风扇联动功能（选配）

根据柜内环境需求，外部风扇（排氢/应急风扇）实现自动循环排氢和强制通风。

排氢功能（选配）：按照柜内环境需求，排氢/应急风机实现自动循环排氢功能，自动循环排氢每次排氢间隔时间为 **24** 小时（可设），排氢运行时间为 **5** 分钟。

应急功能（选配）：在柜内温度过高或者出现系统故障时，同时外部温度较低时，开启应急风机，实现强制通风功能。

3.4 门禁功能（选配）

根据机柜门磁开关上送的信号判定柜门处于开启状态后，空调机组发出告警信号，并停机（可选不停机）

3.5 自测

机组提供自测供现场检测使用。自测过程如下：

1. 在系统功能菜单中选择自测功能，机组自动进入自测程序。
2. 室内风机运行 **30** 秒。
3. 压缩机及室外风机运行 **3** 分钟。
4. 压缩机，室外风机停止,电加热运行 **2** 分钟停止。
5. 若选配了外部风机联动功能，外部风机运行 **2** 分钟（未选配则无此项）。
6. 自测结束，然后按照正常逻辑工作。

3.6 告警信息

机柜空调器提供如下告警信息。设定点参照表 3.1 和表 3.2。

表 3.3 告警内容及参数设置点

告警项目	触发条件	干节点上传
柜内高温	柜内温度达到高温设定点	是
蒸发器冻结	蒸发器表面温度低于 0℃	是
系统频繁高压	高压开关多次动作	是
控制板断电	控制板无电源输入	是
柜内温度传感器故障	传感器线路短路或断路	否

3.7 监控

空调器利用 RS485 通讯口和上位机进行通讯，或者用户可以直接通过显示屏查看空调运行状态，更改空调运行参数。

3.8 机组菜单结构

机组控制器采用 96×32 液晶显示，共 7 个按键来对控制器进行设置，操作界面如下图

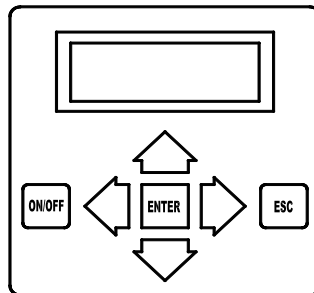

控制器操作界面

ON/OFF: 开/关机键，操作此键（长按，约 5s）对机组进行开/关机；

↑：上移键，选择上一条记录/菜单或者对设置值（仅限密码）进行增加；

↓：下移键，选择下一条记录/菜单或者对设置值（仅限密码）进行降低；

←：左移键，对设置值进行增加或者在进行密码操作时选择前一位数据；

→：右移键，对设置值进行降低或者在进行密码操作时选择后一位数据；

ENTER: 回车键，确认输入；

ESC: 退出键，返回上一屏菜单；

开机后，在任何界面下，若持续 60 秒无键盘操作，自动返回正常显示界面。

系统上电后，按任意键，背光灯亮，如果持续 60 秒无键盘操作，背光灯灭。

机组出厂的操作密码为“0001”。在正常显示界面按回车进入密码输入界面，按左移键，右移键选择需要输入的位，按上下键修改，输入完毕按回车键确认。如果密码不正确，界面显示错误信息，不能修改机组设定。如果密码正确，进入主菜单，可以对机组设定进行编辑。

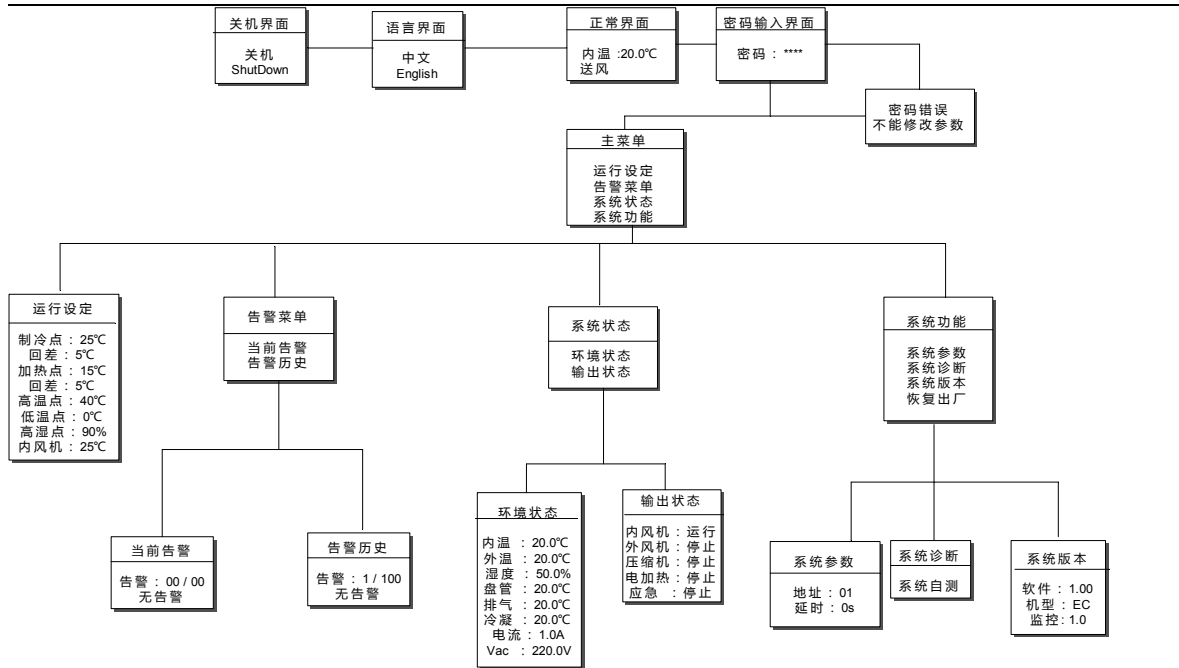

注：此图仅为菜单结构图，不代表出厂参数配置。

4 日常维护

为了保障空调器的正常运行，请参考表 4.1 对空调器进行定期维护

警告：所有的维护工作必须由合格的专业人员进行维护，在进行任何维护前，请事先断开空调器电源和信号线，维护工作结束后接通空调器电源和信号线。

表 4.1 日常维护表

检查项目	步骤内容描述	维护周期
接线	目视检查是否有松脱	12 个月
风机异常	拨动风机，转动是否顺畅，有无异响	12 个月
排水管	目视检查排水管是否有变形，脏堵	6 个月
冷凝器	检查冷凝器清洁状况，用压缩空气清洁冷凝器	6 个月

5 故障及恢复措施

5.1 风机故障及恢复措施

表 5.1 风机故障及恢复措施

现象	可能的原因	检查项目或处理方法
内循环风机不运行	空调属于待机状态	正常现象，空调上电，待机 30s 后，进入自动控制逻辑。
	风机卡死	检查是否有异物卡住风机。
	端子松脱	检查风机对接端子是否松脱。
外循环风机不运行	压缩机未启动	压缩机启动后外风机才启动。
	风机卡死	检查是否有异物卡住风机。
	端子松脱	检查风机对接端子是否松脱。
风扇异响	风机轴承磨损	更换风机。
	扇叶刮擦其它物体	检查是否有线缆等与风机扇叶干涉。
外部风机不工作	工作条件不满足	是否满足外部风机开启条件。
	电源中断	检查外部电源。
	风机故障	更换风机。
	默认不开启	确认是否配置外部风机联动功能

5.2 制冷系统故障及恢复措施

表 5.2 制冷系统故障及恢复措施

现象	可能的原因	需检查项目或处理方法
压缩机不启动	未开电源（待机）	检查主电源开关，并检查操作显示界面，是否已经开机。
	电路连接松动	紧固电路接头。
	压缩机电机烧坏	检查电机，如发现缺陷，立即更换。
压缩机不工作	无冷却需求	检查柜内温度显示及操作界面中压缩机的输出状态。
	停机延时	压缩机在正常状态下具有最短停机时间，如果温度在此期间内温度重新升高到开启点，压缩机仍然会延时开启。
排气压力高	冷凝器脏堵	清洁冷凝器。
	外循环风机不运转	参考表 5.1。
蒸发器冻结	内循环风机不运转	参考表 5.1。
	盘管温度传感器故障	检查接线是否正常，否，则更换盘管传温度感器

Declaration:

This manual shall not be reproduced without the written approval of Envicool.

Envicool reserves the right to update the product without notice.

声明:

版权所有，禁止任何未经授权的拷贝和抄袭。

厂家对产品持续升级进行的资料更改，恕不另行通知

Shenzhen Envicool Technology Co., Ltd.

Building 9, Hongxin Industrial Park, Guanlan,

Bao'an District, Shenzhen

Tel: 86-755-29588896

Fax: 86-755-29588895

Website: <http://www.envicool.com>

深圳市英维克科技股份有限公司

深圳市宝安区观澜街道鸿信工业园 9 栋

电话: 0755-29588896

传真: 0755-29588895

网址: <http://www.envicool.com>