

GRESCHING

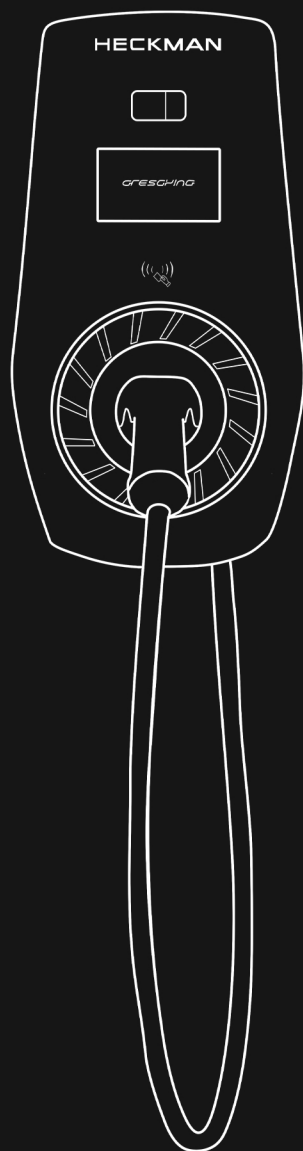

INSTRUKCJA OBSŁUGI

Smart AC Charging Point

H2-11T11

Please read carefully to understand the correct use of the device before installation, maintenance and operation!

Please follow the safety notes; otherwise, it may lead to a danger of death, injury and damage to the device, supplier cannot accept any liability for claims resulting from this .

Thank you very much to use our AC Charging Point

- This manual describes the installation, use and maintenance of AC Charging point. This manual is intended for installation and maintenance personnel.
- The text and illustrations in this user manual are general explanations of these type of equipment, and the actual product may be inconsistent with this manual in detail .

Safety notes

- ⚠ Leave no inflammable or explosive substances near the EV Charging point; otherwise, hazardous bias! may result.
- ⚠ Installation and wiring should be done by personnel with professional qualification, otherwise, hazardous electric shock may result.
- ⚠ Make sure input power supply is entirely disconnected before wiring; otherwise, hazardous electric shock may result.
- ⚠ Earth terminal of the EV Charging point must be grounded securely; otherwise, hazardous electric shock may result.
- ⚠ The lead nose of the charging point must be securely attached or there is a risk of damaging the equipment.
- ⚠ Leave no metals such as bolts, gaskets into the inside of the EV Charging point; otherwise, hazardous blast and fire may result.
- ⚠ Strictly forbidden for minors or persons of restricted capacity to approach the charging point to avoid injury .
- ⚠ Forced charging is strictly forbidden when the electric vehicle or charging point fails .

- ⚠ It is strictly prohibited to use the charging point when the charging adapter or charging cables are defective, cracked, worn, broken or the charging cables is exposed. If you find any, please contact the supplier in time .
- ⚠ EV can only be charged with the engine off and stationary .
- ⚠ Accessory replacement must be done by qualified personnel, thrums or metals are prohibited to be left in the controller; otherwise, hazardous blast and fire may result.
- ⚠ It is recommended that routine safety inspection visits to charging point be conducted at least once a week .
- ⚠ Keep the charging connector clean and dry and wipe with a clean, dry cloth if soiled.

Product pictures are shown in Figure 1-2 and Figure 1-3 below:



Case B connection
Figure 1-2 Socket Version



Case C connection
Figure 1-3 Cable Version

Specifications

Table 1- 1 Specification

AC Power supply	H1-EU7-xxx	1P + N + PE
	H1-EU11-xxx,H1-EU22-xxx	3P + N + PE
Rated Power	H1-EU7-xxx	7.4kW
	H1-EU11-xxx	11kW
	H1-EU22-xxx	22kW
Rated Voltage	H1-EU7-xxx	AC 230V, 50/60Hz
	H1-EU11-xxx,H1-EU22-xxx	AC 400V, 50/60Hz
Rated Current	H1-EU11-xxx	16A
	H1-EU7-xxx,H1-EU22-xxx	32A
Charge system	Mode 3	
Socket/ Cable	H1-EUxx-Bxx	Type 2 Socket, Case B connection
	H1-EUxx-Cxx	Type 2 Socket, Case C connection
Charging Control	APP,RFID,plug&play	
Display Screen	H1-EUxx-xLxx	3.8-inch LCD screen
Indicator Light	H1-EUxx-xxx	LED lights
Communication	WiFi/BT, 4G, LAN	Interface
Communication	OCPP 1.6J	Protocol
Safety Protection	Over current protection, over voltage protection, under voltage protection, over temperature protection, leakage protection, unconnected PE ground protection etc.	
RCD	TypeA(30mA) + DC 6mA built-in	
Altitude	2000m	
Storage temperature	-40~75°C	
Operation temperature	-30-50°C	
Relative humidity	95%RH, No water droplet condensation	
Vibration	0.5G, No acute vibration and impaction	
Installation location	Indoor or outdoor, good ventilation, no flammable, explosive gases	
Product Net Weight	H1-EU22-Bxx	2.6KG
	H1-EU11-Bxx	2.4KG
	H1-EU7-Bxx	2.4KG
	H1-EU22-Cxx	5KG
	H1-EU11-Cxx	3.8KG
	H1-EU7-Cxx	4KG
Product size	H1-EU-Bxx	Height: 388.45mm Width: 202.45mm Depth: 116mm
	H1-EU-Cxx	Height: 388.45mm Width: 202.45mm Depth: 107.26mm
Packaging box dimensions	H1-EU-Bxx	Height: 455 mm Width: 260 mm Depth: 150mm
	H1-EU-Cxx	Height: 455mm Width: 260mm Depth: 230mm
Mounting	Wall-mounted or pole-mounted (mounting pole is optional)	
IP Code	IP55	

2. Installation

2.1. Included Mounting Parts And Required Tools

Components

Make sure that all parts are delivered according to the order. Check the packaging for the following parts.

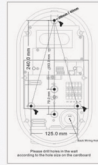

Wall anchors (8 x 40 mm)

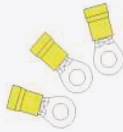

Insulated ring terminals



Screws (Φ5 x 40 mm)



Waterproof gaskets

Required tools



Measuring tape



Electric drill



Hammer



Slotted screwdriver



Phillips head screwdriver



Wire stripper



Crimp tool



Utility knife



Φ8mm drill bit



1-1/8 in. (35mm) step drill bit



Step Bit, 1-1/8 in(29mm)



Step Bit, 1-1/8 in(35mm)



Computer (with Wi-Fi)

2.2. Installation steps

2.2.1 Cut the drilling template from the carton, place the drilling template on the wali , drill holes where the three fixing points, insert the Wall plugs into the fixing holes.

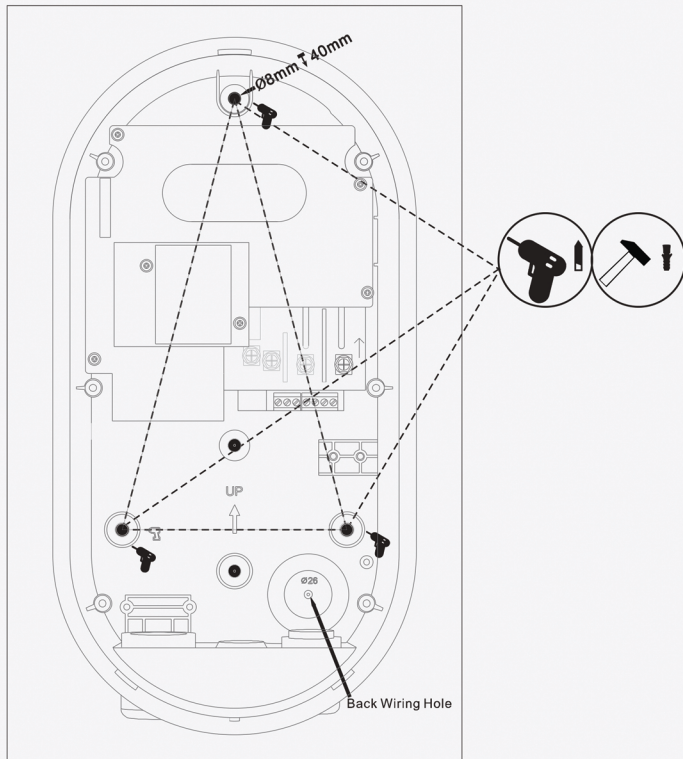

Figure 2-3 Locate the installation location for Wall-mounted

2.2. Installation steps

2.2.1 Cut the drilling template from the carton, place the drilling template on the wall, drill holes where the three fixing points, insert the Wall plugs into the fixing holes.

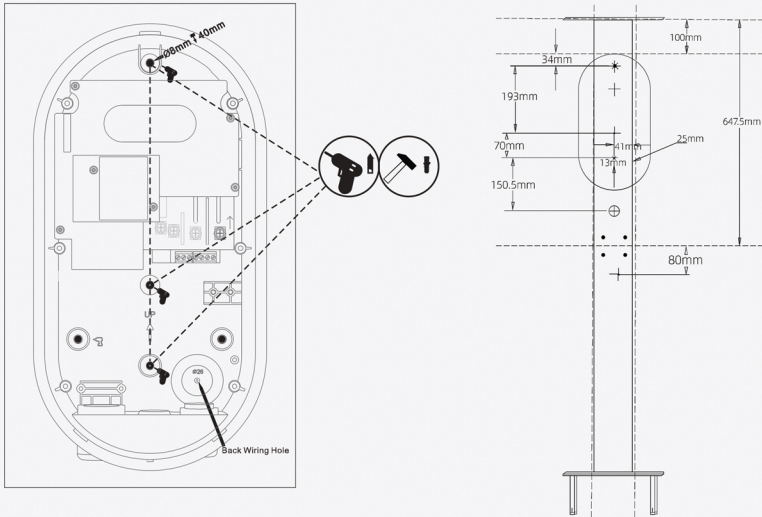
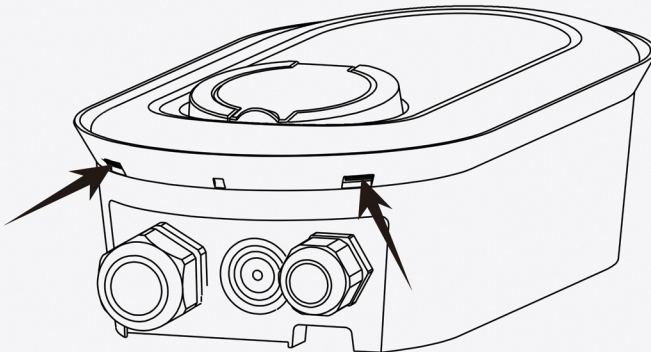
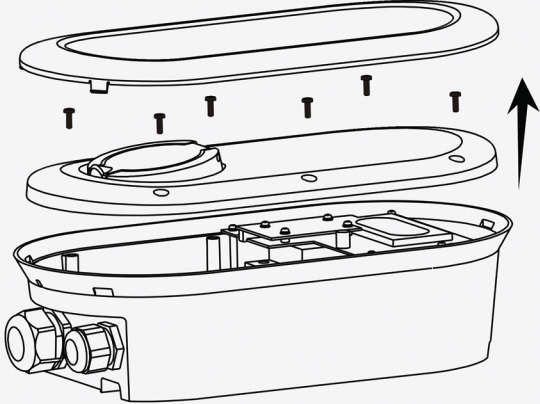

Figure 2-4 Locate the installation location for pole-mounted

2.2.2 Use a screwdriver to carefully push the two barbs at the bottom of the equipment and remove the upper cover.



2.2.3. Loosen the six screws and carefully remove the second cover from the base box.



2.2.4. Fix the device on the wall by inserting the screws and waterproof gaskets

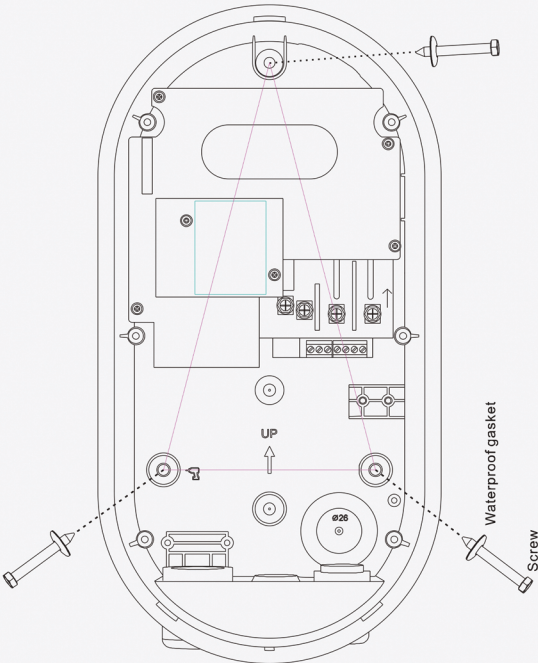

2.2.5. Wiring diagram, Electrical Wiring

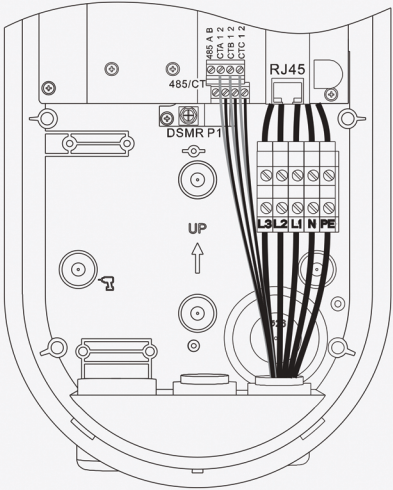

2.2.6. Put back the cover, screw back the cover screws buckle the front cover.

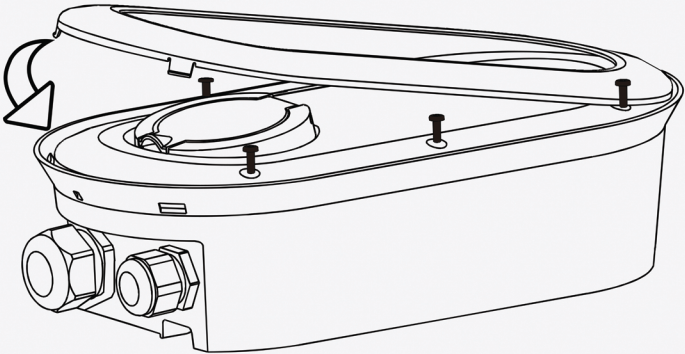

Configuration

Install EVSElink Charge App

1. Download the EVSElink Charge app to your mobile device from the Google Play or Apple App Store.

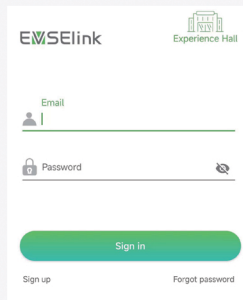

Figure 3-1 EVSElink app

2. Open the app, sign in or create an account with your and email.

Add the Charger

1. Sign up with your e-mail
2. Next please go to the APP to retype the E-mail and password, sign in.



3. Add the charger with the SN code on your EV charger.

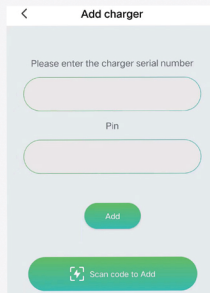

4.You will go to the home interface to set the parameters of the EV charger.

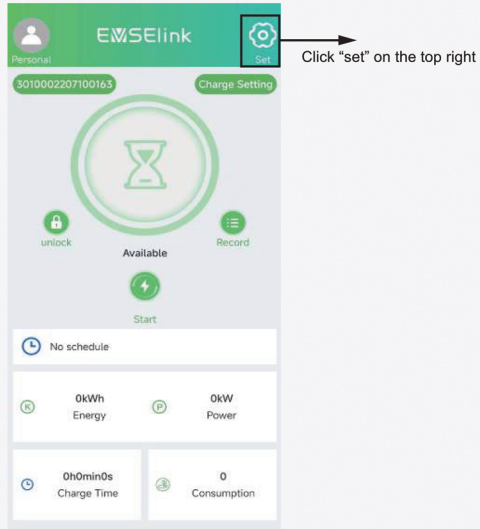

5.Set the parameters of the EV charger via Bluetooth.

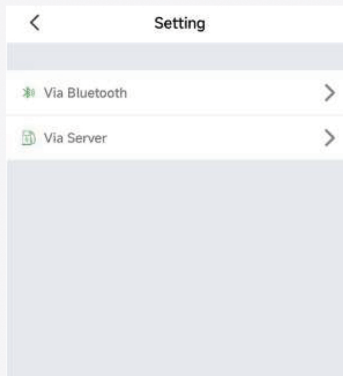

6. Here is a introduction of the settings.

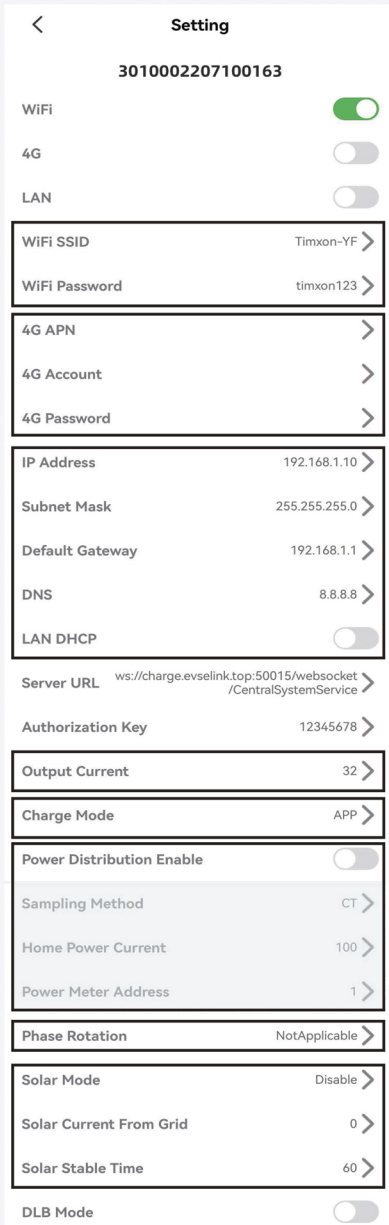

→ Set the wifi

→ Set the 4G

→ Set the LAN

→ Set the Current

→ Optional App,RFID or plug&play mode

→ Set the DLM

→ Set Power line Phase Rotation

→ Set local Solar

CT Clamp (optional)

The CT clamp can measure current up to 120A.



Installation instructions

Please refer to the schematic diagram below for the interface position of CT clamps in the charger.

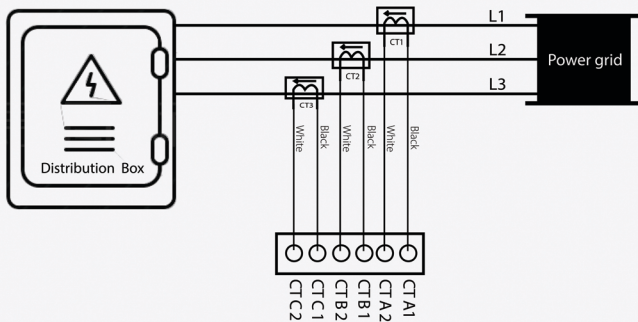

- For a single-phase charge point, the CT clamp is connected to CTA, the black wire is connected to 1, and the white wire is connected to 2. The CT clamp is connected to the main incoming line of the home power grid. The incoming line phase of the CT clamp is the same as the phase of the power supply line of the charge point.
- For a three-phase charge point, the three CT clamps are connected to CTA, CTB, and CTC respectively, the black wire is connected to 1, the white wire is connected to 2, the CT clamps are hung at the main incoming line of the home grid, CTA is connected to L 1, CTB is connected to L2, and CTC is connected to L3.

CT-HUB Product Diagram

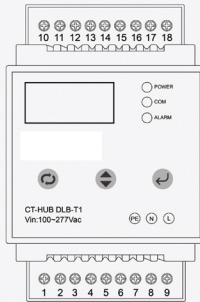

Installation instruction

1.Installation wiring diagram

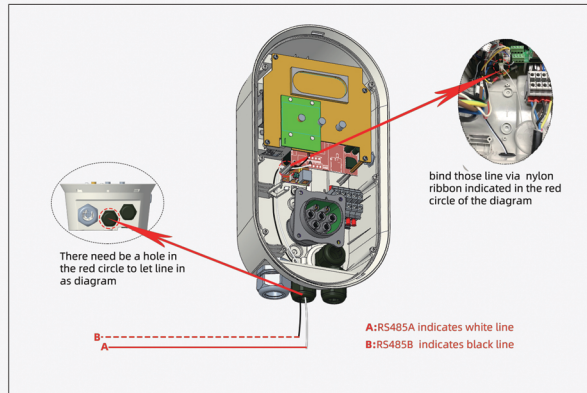
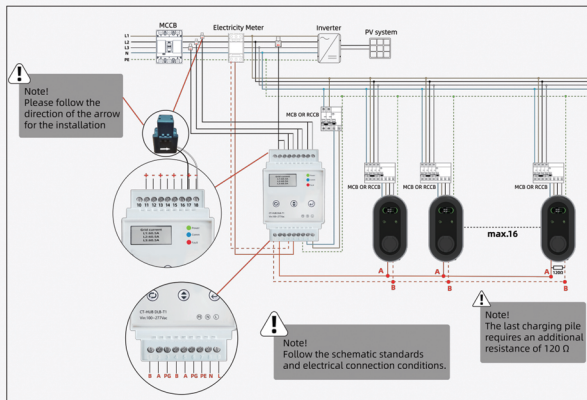

User Interface Instruction

LCD Display Cover





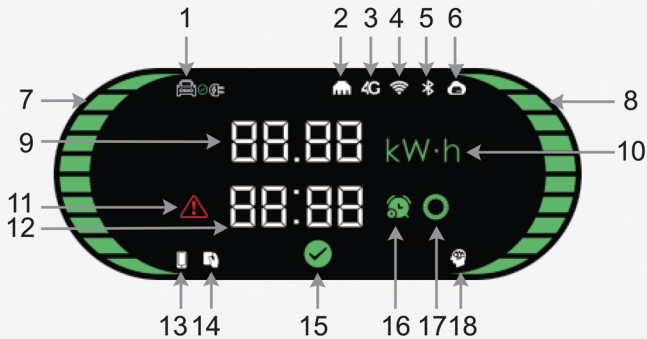

Applicable to the LCD display cover version (EAW-AS11W102-20 and EAW-AS09P102-20), skip if you are using a LED display cover version.

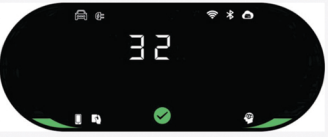

1. LCD 2. RFID reader 3. Touch Button 4. Connector

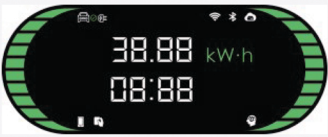

- | | | |
|------------------|--------------------------------|--------------------------------|
| 1. EV connection | 7. Left status bar | 13. Mobile app control |
| 2. LAN | 8. Right status bar | 14. RFID reader |
| 3. 4G | 9. Energy, power/rated current | 15. Available indicator |
| 4. Wi-Fi | 10. Energy/Power unit | 16. Reservation time indicator |
| 5. Bluetooth | 11. Fault indicator | 17. Waiting indicator |
| 6. CMS | 12. Time or fault code | 18. Smart charger indicator |

Display	Status	Description
	Available	<ul style="list-style-type: none"> * Not connected to EV * Display rated current (A)
	Charging ready	<ul style="list-style-type: none"> * Charger is ready * Connected to EV * Display rated current (A) * Display time (minutes)
	Charging	<ul style="list-style-type: none"> * Charging in progress * Display charging power (kW) and charging energy (kWh) in turn * Display charging time (minutes) * The left and right status bars indicate charging
		
	Charging paused	<ul style="list-style-type: none"> * Charging paused * Display charging energy (kWh) * Display charging time (minutes) * Display a waiting indicator
	Charging ended	<ul style="list-style-type: none"> * Charging ended * Display charging energy (kWh) * Display charging time (minutes)
	Scheduled charging	<ul style="list-style-type: none"> * Scheduled charging * Display the scheduled time (minutes)
	Fault or Unavailable	<ul style="list-style-type: none"> * Fault * Display fault code. Refer to Troubleshooting for its meaning.

LED Display Cover

Applicable to the LED display cover version (EAW-AS11W102-10 and EAW-AS09P102-10)



1. LED 2. RFID reader 3. Touch Button 4. Socket

LED description

LED	Description
Solid yellow	APP Mode: Not connected to EV and not connected to the app
Solid blue	APP Mode: Not connected to EV but connected to the app RFID or Plug & Charge Mode: Not connected to EV
Flashing blue	Connected to EV
Slow flashing blue	A schedule is active
Glowing green	Charging in progress
Flashing green	Charging ended
Solid red	Unavailable
Fast flashing red	Firmware update in progress
Red flashing once	Error: error code 1
Red flashing twice	Error: error code 2
Red flashing 3 times	Error: error code 3
Red flashing 4 times	Error: error code 4
Red flashing 5 times	Error: error code 5
Red flashing 6 times	Error: error code 6
Red flashing 7 times	Error: error code 7
Red flashing 8 times	Error: error code 8

Red flashing 9 times	Error: error code 9
Red flashing 10 times	Error: error code 10
Red flashing 11 times	Error: error code 11
Red flashing 12 times	Error: error code 12
Red flashing 13 times	Error: error code 13

Charging

DANGER

The H1-EU (Smart AC charging point) is an AC charging point that you can use to supply electricity to an EV. The H1-EU offers tailor-made, intelligent and network charging solutions for your company or home. The H1-EU can connect to the internet via WiFi, 4G or LAN. The model number definition of charging point follows the rules as shown in Figure 1- 1

Plug and Charge Mode

1. Start charging
 - Remove the connector from the holster.
 - Plug the connector into your EV charging port. The charger will automatically start charging once the connector is properly connected.
2. Stop charging
 - Press the touch button.
 - Carefully remove the connector from EV and stow the cable in the cable holster.

Troubleshooting and Maintenance

Troubleshooting

Error Code	Error Description	Troubleshooting Suggestions
1	Leakage	<ul style="list-style-type: none"> • Disconnect the leakage/over-current protection, switch off the distribution box immediately • Check whether the charger's output cable is damaged or has low-impedance ground or short circuit • After troubleshooting the above problems, power on the charger again. If the problem still exists, contact customer support
2	Over current	<ul style="list-style-type: none"> • Check whether the charging connector is correctly connected. • Check whether the OBC (On-board Charger) is normal
3	Ground fault	<ul style="list-style-type: none"> • The charger is not grounded. Check the input power cable. • In case of a single live wire, make sure that the L and N wires are not wired in reverse.
4	Over voltage or under voltage	<ul style="list-style-type: none"> • Check whether the input cable is property connected. • Check whether the voltage on the power input is too high or not sufficient. If yes, contact local power grid company
5	Relay welding or breaking	<ul style="list-style-type: none"> • Power off and restart the charger. If the problem still exists, contact customer support
6	Abnormal CP (Control Pilot)	<ul style="list-style-type: none"> • Check the charging connector and charging socket of your EV • Disconnect and reconnect the charging connector
7	electronic lock fault	<ul style="list-style-type: none"> • Check that the electronic lock connection is reliable
8	Over temperature	<ul style="list-style-type: none"> • The ambient temperature is too high.Please keep it at 50 degrees Celsius
9	Emergency Stope	<ul style="list-style-type: none"> • Check that the emergency stop switch is pressed(Optional)
10	Tamper Detectede	<ul style="list-style-type: none"> • Check that the charger cover is closed(Optional)
11	Energy meter communication fault	<ul style="list-style-type: none"> • Check whether the communication cable of the chargermeter is properly connected or loose • Check that the baud rate of the meter is 9600(Optional)
12	Diode missing	<ul style="list-style-type: none"> • No vehicle diode detected, If it is not a real car, pleaseconfirm the presence of a diode
13	DLB communication fault	<ul style="list-style-type: none"> • Please check whether the RS485 communication cable is connected correctly

Maintenance

To ensure long-term stable operation of the equipment, the equipment does require some basic, common sense maintenance. The exterior maintenance can be performed by the user. All other service must be conducted by qualified personnel. It is recommended to perform a maintenance every month depending on the environment.

- To avoid accumulation of debris/dust/dirt on or around the unit, wipe surfaces with a soft cloth dampened with water, or for harder to remove marks, use an alcohol based cleaner.
- Check whether the equipment is properly grounded and safe.
- Check whether there are potential safety hazards like flammable, explosive, harsh or combustible materials around the charger. If present, clear the materials.
- Check for debris or damage inside or around the cable and connector. If present, remove debris and/or contact a qualified personnel for help.
- Check for loose connections. If present, unplug the cable and re-insert it.

Warranty

EVSElink offers a limited 3-year wallbox warranty and 1-year plug and cable warranty from the date of purchase of the equipment.

The limited warranty does not apply to, and EVSElink will not be responsible for, any defect in or damage to the charger: (1) that has been misused, neglected, tampered with, altered, or otherwise damaged, either internally or externally; (2) that has been improperly installed, operated, handled or used, including use under conditions for which the product was not designed, use in an unsuitable environment, or use in a manner contrary to the User Manual or applicable laws or regulations; (3) that has been subjected to fire, water, generalized corrosion, biological infestations, acts of God, or input voltage that creates operating conditions beyond the maximum or minimum limits listed in the specifications; or (4) that has been subjected to incidental or consequential damage caused by defects of other components of the electrical system.

If you have any questions, please contact us via email.

GRESPING

Notatki serwisowe

GRESPING

Notatki serwisowe

GRESGING

Notatki serwisowe

