

# HECKMAN

TECHNOLOGY serves MAN

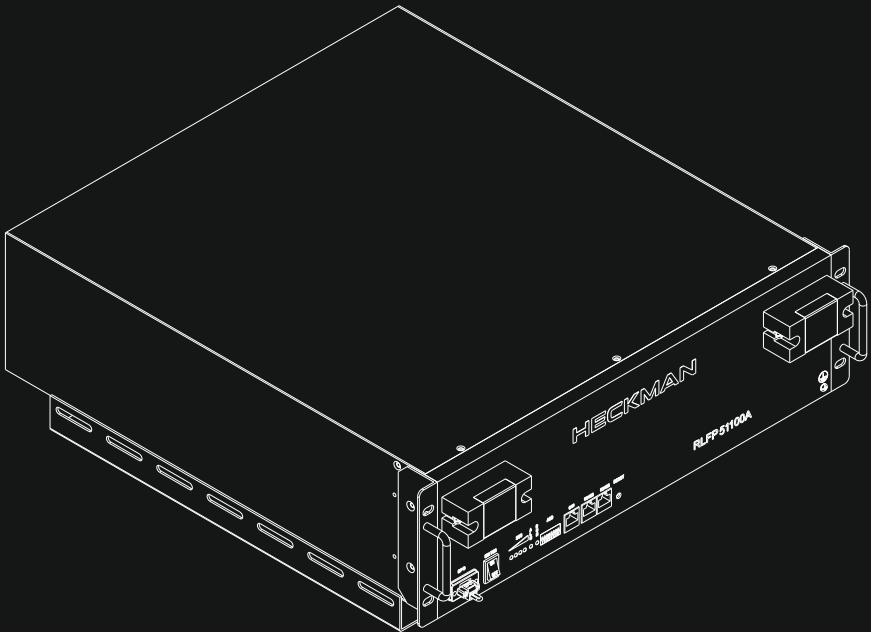

## USER MANUAL

Energy Storage  
**RLFP51100A**

**HECKMAN**

TECHNOLOGY serves MAN

## Contents

<b>1. Guide to the safe use of lithium-ion batteries</b>	<b>4</b>
<b>2. Product presentation</b>	<b>6</b>
2.1 Product appearance	6
2.2 Product features	7
2.3 Principles of product operation	8
2.4 User's manual for the device's front panel 2.5	9
Product technical parameters	15
<b>3. Product installation</b>	<b>17</b>
3.1 Devices and tools	18
3.2 Cleaning	18
3.3 Specifications	18
3.4 Installation method	19
3.5 Communication with the inverter	20
<b>4. Product use</b>	<b>21</b>
4.1 Detailed product manual	21
4.2 Sleep and wake-up functions	22
<b>5. The most common faults and their removal</b>	<b>22</b>
<b>6. List of items in the package</b>	<b>23</b>
<b>Declaration of Conformity</b>	<b>24</b>
<b>Guarantee</b>	<b>25</b>
<b>Inspection card</b>	<b>28</b>
<b>Service notes</b>	<b>29</b>

## 1. Guide to the safe use of lithium-ion batteries



### Warnings:

1. Read the user manual carefully before installing and using the battery. Failure to follow the instructions or warnings contained in this document may result in damage to the battery or the entire system, and may result in electric shock, serious injury or even death.
2. The product is intended for use in low voltage energy storage systems in buildings. Do not use it in other places.
3. It is prohibited to use any cleaning agents to clean the faucet.
4. It is prohibited to expose batteries to flammable or irritating chemicals or vapors.
5. The battery installation environment should be away from fire and water.
6. It is prohibited to paint any part of the battery, including any internal or external components.
7. Direct connection of batteries to photovoltaic panels is prohibited.
8. It is prohibited to connect the battery directly to an AC power source.
9. It is prohibited to introduce any foreign objects into any part of the battery.
10. It is prohibited to switch the breaker on an inactive product. This prevents battery power from being consumed.
11. If the battery is not used for a long time, please recharge it every 6 months, with each SOC charge not less than 90%.
12. The battery must be charged within 12 hours after the activation of the discharge protection.
13. With the battery output DC voltage above 48V, please pay special attention to personal safety.
14. Disconnect all terminals before battery maintenance.



**Before connecting:**

1. After opening the package, inspect the product and checklist. If you notice damage to the product or missing components, please contact the seller or distributor.
2. Before installation, please disconnect the external battery power and make sure the battery is turned off.
3. Connect the cables correctly. You need to be careful to avoid mistakes related to the polarity of the positive and negative wires. Make sure there are no short circuits with external devices.
4. Do not connect the battery directly to the mains power supply.
5. When connecting batteries to the system, make sure the system is well grounded.
6. Ensure that the electrical performance of the battery system is compatible with the associated devices.



**During use:**

1. When moving or repairing the battery, please turn off the power and turn off the battery completely.
2. Do not mix different types of batteries.
3. Do not use the battery with a damaged or incompatible inverter.
4. Do not disassemble the battery into individual components.
5. In the case of fire, use an appropriate fire extinguishing tool for lithium batteries.
6. Only authorized personnel should open, repair, or disassemble the battery. The seller is not responsible for failure to comply with the requirements and safety standards related to the design, production, and use of devices.
7. Failure to comply with the rules contained in the manual may constitute grounds for loss of warranty.

## 2. Product presentation

The RLFP51100A is a lithium iron phosphate (LiFePO<sub>4</sub>) battery designed for building energy storage systems. It is an advanced product developed in response to new trends and developing needs in the field of energy storage, as well as requirements for new types of backup power supply. The product has the features of integration, miniaturization, lightness, intelligence, standardization and was created in accordance with environmental protection requirements. It can be used with a wide range of devices such as inverters, photovoltaic modules, etc., in various fields of building energy storage. It has certificates: CE, UL, IEC, UN 38.3, etc.

### 2.1 Product appearance

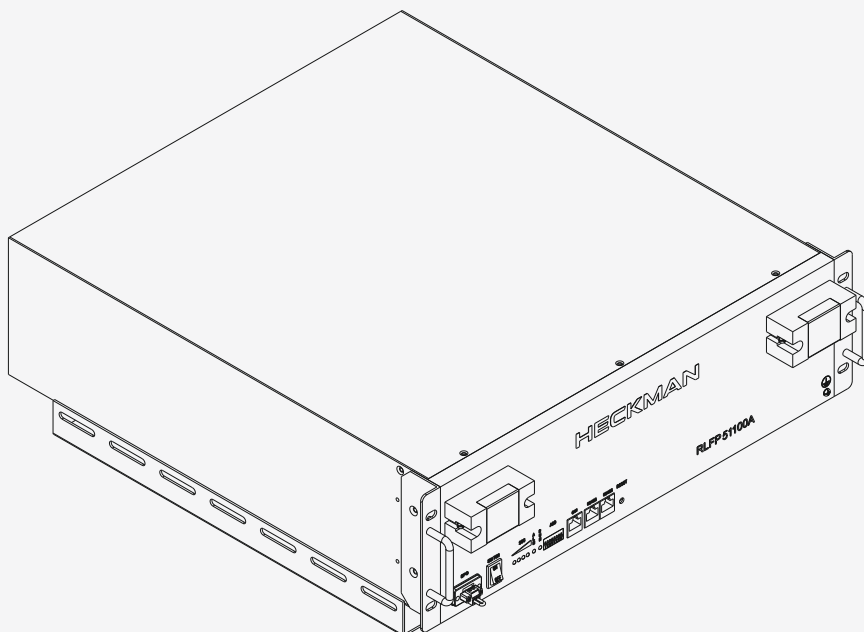

**Note:** Due to product updates, any changes will be implemented without additional notice. The actual deliveries of the product will be decisive.

## 2.2 Product features

- n Small size, light weight, safe and reliable, eco-friendly, with a long device life.
- n High energy density, stablee tension, support for fast charging and discharging.
- n Wide range of operating temperatures.
- n Installation in rack cabinets.
- n Possibility to combine multiple modules to increase capacity according to system requirements.
- n Extensive alarm and protection functions against overload, overcharge, over-discharge, short circuit, high temperature, low temperature **with** balancing functions and overcurrent protection.
- n RS-485 and CAN interfaces for digital communication with parallel modules and inverter.
- n External Power Off (EPO) connector enabling remote battery shutdown.

## 2.3 Principles of product operation

The main purpose of the product is to provide emergency power to building equipment via an inverter. Thanks to the inverter settings, you can select the power source for electrical devices - from the power grid or batteries. The battery is charged from photovoltaic panels and the power grid.

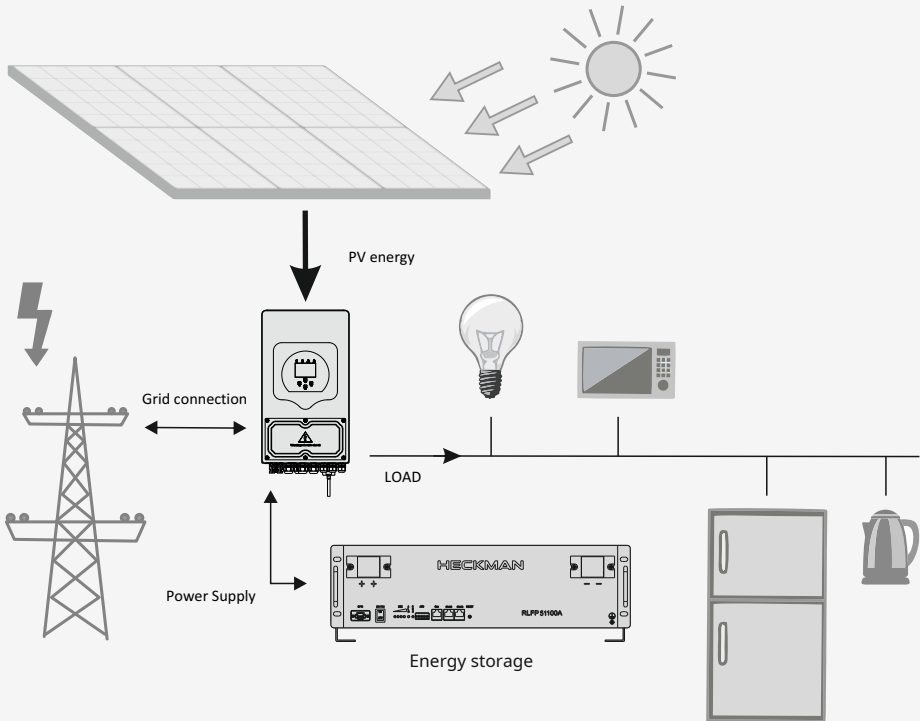

## Product architecture

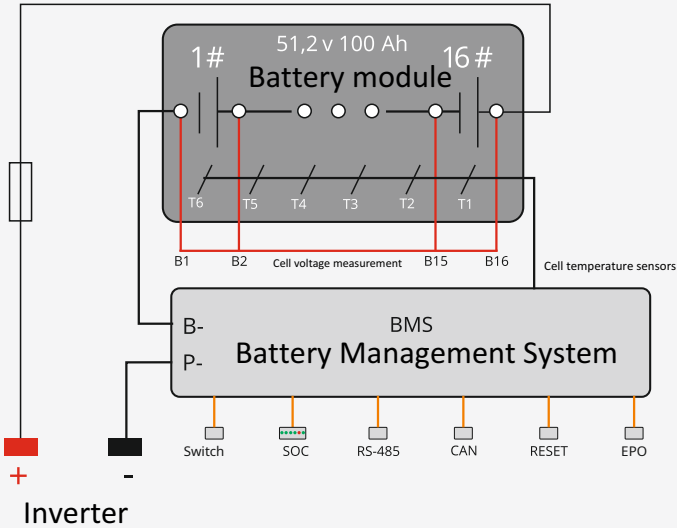

## 2.4 User's manual for the device's front panel

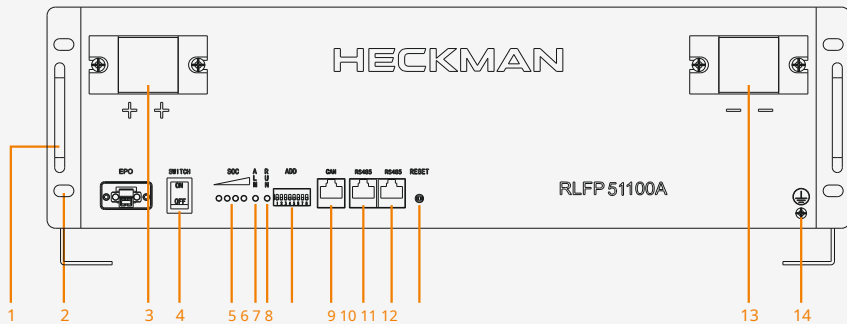

### Panel interface description:

1. Handle for easy transport and installation.
2. Mounting bracket. Compatible with standard 19" rack cabinets.
3. Positive terminal - positive input and output of the battery.

4. Switch - When the BMS switch is turned off, the BMS goes to sleep while simultaneously turning off the charge and discharge MOSFETs.  
After starting the system, the device goes to normal operation mode.
5. The battery level indicator consists of four green LEDs that show the current battery level (from left to right LED1-LED4).

State	Landing				Discharging			
Indicator capacity	L1 ●	L2 ●	L3 ●	L4 ●	L1 ●	L2 ●	L3 ●	L4 ●
0~25%	flash.	off	off	off	incl.	off	off	off
25~50%	incl.	flash.	off	off	incl.	incl.	off	off
50~75%	incl.	incl.	flash.	off	incl.	incl.	incl.	off
75~100%	incl.	incl.	incl.	flash.	incl.	incl.	incl.	incl.
Capacity indicator whip.●	constant light				flash. 2			

6. Alarm indicator – red LED; details are in the table below.

7. Operation indicator – green LED; details are in the table below.

System state	Defence / alarm / normal	RUN	ALM	lvl. chg. bat. LED				Instruction
		●	●	●	●	●	●	
Off	sleep mode	off	off	off – no light				The device is in sleep mode
Mode stand by	normal	flash. 1	off	table point 5				The device is in standby mode
	alarm	flash. 2	flash. 2	table point 5				The device is in fault mode. The battery should be restarted. If the problem persists, contact an authorised Heckman service centre

System state	Defence / alarm / normal	RUN	ALM	lvl. chg. bat. LED				Instruction
		●	●	●	●	●	●	
Charge	normal	all the time	off	table point 5				The battery is charging in normal mode
	alarm	all the time	flash. 2	table point 5				Battery works on overload limit
	protection from overloading	all the time	off	all the time				Battery fully charged charged
	battery overload	off	all the time	off				The device is in failure mode. You should restart the battery. If the problem happens repeats, you should to contact with an authorized person Heckman service
Discharge	normal	flash. 2	off	table point 5				The battery is running low in normal mode
	alarm	flash. 2	flash. 2	table point 5				Battery works on overload limit
	protection from overvoltage, short circuit, inverted connection and other types overload	off	all the time	off				The device is in fault mode. The battery should be restarted. If the problem persists, contact an authorised Heckman service centre

### LED-based device mode

Flicker mode	HE	OFF
Flash. 1	0.25 sec	3.75 sec
Flash. 2	0.5 sec	0.5 sec

8. DIP code switch - an 8-bit binary code switch is used, which is used to set the product addresses when connected in parallel.

**Definition of bits 1–8 of the code switch:**bits 1–4 are used to set device addresses *slave*, and bits 5–8 set the number of all devices on the device*master*.

**Configuration on slave devices (*slave*):**bits 1 to 4 are set according to the device order, and the slave address range is 1 to 15. Bits 5 to 8 are fixed and equal to 0 (see slave configuration table).

**Master device configuration (*master*):**bits 1 to 4 equal 0, and the address of the main device is fixed and equals 0. Bits 5 to 8 are set according to the number of all devices connected in parallel*master + slave* (see host device configuration table).

## Slave configuration table

Address	DIP code switch position				Description
	#1	#2	#3	#4	
1	HE	OFF	OFF	OFF	address 1
2	OFF	HE	OFF	OFF	address 2
3	HE	HE	OFF	OFF	address 3
4	OFF	OFF	HE	OFF	address 4
5	HE	OFF	HE	OFF	address 5
6	OFF	HE	HE	OFF	address 6
7	HE	HE	HE	OFF	address 7
8	OFF	OFF	OFF	HE	address 8
9	HE	OFF	OFF	HE	address 9
10	OFF	HE	OFF	HE	address 10
11	HE	HE	OFF	HE	address 11
12	OFF	OFF	HE	HE	address 12
13	HE	OFF	HE	HE	address 13
14	OFF	HE	HE	HE	address 14
15	HE	HE	HE	HE	address 15

10. RS-485 – port for cascade communication, enabling data transmission between devices via the RS-485 interface.

PIN	Definition
PIN 2, 7	485-1A
PIN 1, 8	485-1B
PIN 6	485-2A
PIN 5	485-2B

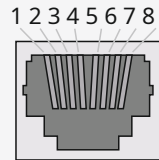

11. EPO - External Power Off connector, remote battery shutdown. Possibility to connect an external relay controlling battery shutdown, e.g. for fire protection systems.

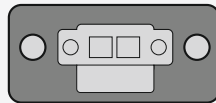

Opening the EPO contact will turn off the battery. Shorting the EPO contact makes it possible to turn the battery on and off using the switch (4). If no external switching device is connected, use the cable bridge included in the set.

12. The reset button combines three functions: activation, sleep and reset.

Functions	Definition
Activation	If the BMS is in the sleep state, when you press this button, the BMS will be activated and the LEDs will flash sequentially and then enter the normal working state.
Sleep mode	If the BMS is in standby or discharge mode, it will enter sleep mode after pressing this button for 3 seconds. After the LED flashes again, the BMS goes into sleep mode.
Reset	If the BMS is in standby or charging/discharging mode, it will be reset after pressing and holding this button for 3 seconds.

13. Negative terminal - negative input and output of the battery.

14. The ground terminal is for grounding connection.

## 2.5 Product technical parameters

Before installing and using this product, please carefully set the appropriate inverter parameters according to the given specifications. The set parameters of the product cannot be changed arbitrarily, otherwise it will seriously affect the performance and functionality of the product!

### Basic product parameters

Model and specifications	RLFP51100A
Battery type	LiFePO4 battery in a packet arrangement
Nominal voltage	51.2V
Nominal capacity	100 Ah
Storage capacity	5120 Wh
Battery dimensions	width 482 × depth 485 × height 133 mm
Weight	54kg
Working temperature	- 15–60°C
Operating relative humidity	≤90–40°C±2°C
Height above sea level	0–3600 m
Working atmospheric pressure	70 kPa–103 kPa
Noise level	0 dB

### Charging technical parameters

Model and specifications	RLFP51100A
Charging current	≤100 A
Charging current value with limitation	10A
Single cell overvoltage alarm	3.50 V
Overvoltage alarm delay time single cell	2000 ms
Protection against single cell overvoltage	3.60V
Excess protection delay time voltage of a single cell	1000 ms
Total overvoltage alarm	56 V
Alarm delay time excessive total voltage	1000 ms
Protection from excessive total voltage	57 V

Model and specifications	RLFP51100A
Excess protection delay time total voltage	1000 ms
Over charging current alarm	100 A
Excess alarm delay time charging current	1000 ms
Protection against excessive charging current	110A
Over charging current protection delay time	10,000 ms
High charging temperature alarm	50 <sub>...c</sub>
Low charging temperature alarm	2 <sub>...c</sub>
Protection against high charging temperatures	55 <sub>...c</sub>
Low charging temperature protection	0 <sub>...c</sub>

## Discharge technical parameters

Model and specifications	RLFP51100A
Discharge current	≤100 A
Over-discharge alarm single cell	3 V
Single cell over-discharge alarm delay	2000 ms
Protection against excessive discharge of a single cell	2.90V
Delay protection against excessive discharge of a single cell	1000 ms
Alarm for excessive discharge of the entire battery	48 V
Full battery over-discharge alarm delay	1000 ms
Protection against excessive discharge of the entire battery	46.4V
Overload protection delay discharging the entire battery	1000 ms
Excessive discharge current alarm	105A
Over discharge current alarm delay	1000 ms
Protection against excessive discharge current	110A
Overload protection delay discharge current	10,000 ms

Model and specifications	RLFP51100A
High temperature alarm when discharging	52°C
Low temperature alarm during discharge	- 10°C
High temperature protection during discharge	60°C
Protection against low temperature during discharge	- 15°C

### 3. Product installation



#### Attention:

1. The installation processes, commissioning and maintenance of the product should be carried out by trained personnel. Before installing and using the product, carefully read and understand the safety instructions and product installation procedures. It is necessary to strictly follow the relevant safety regulations to avoid incorrect operations that may result in personal injury or product damage.
2. Before installation, please check whether the inverter and product are turned off.
3. Check that the cables are properly insulated and avoid situations where metal parts of the cables are exposed.
4. During installation, ensure that the photovoltaic energy storage system is properly grounded.

#### Product dimensions:

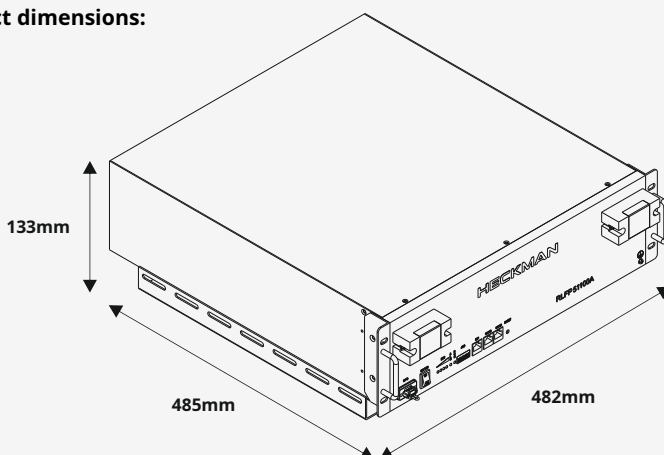

## 3.1 Devices and tools

Suggested safety tools and materials for product installation:



Screwdriver



Multimeter



Iso-gloves



Goggles



Iso-footwear



### Attention:

Use appropriate insulated tools to prevent accidental electric shock or short circuit.

## 3.2 Cleaning

Cleanliness conditions affect the insulation performance of the system, therefore, before installing and commissioning the system, it is necessary to remove dust and iron shavings. The working environment must not be dusty and must have certain anti-dust properties. During continuous operation of the system, dust and humidity levels should be checked regularly to ensure a clean working environment.

## 3.3 Specifications

1. First, check that the product packaging is not damaged and meets the required specifications.
2. After opening the package, check that all items are complete and in good condition according to the checklist prepared during packing.
3. Remove items from the packaging carefully so as not to damage their surface, which may affect their aesthetics.
4. Make sure that the connecting cable used is of the appropriate diameter.

5. Before use, ensure that all metal tools are insulated.
6. The arrangement of cables should be well thought out and orderly organized.  
Protection against moisture and corrosion should be considered.
7. After installation, check that all connection screws are securely tightened and that the connectors are stable.

### 3.4 Installation method



## 3.5 Communication with the inverter

Connecting one device:

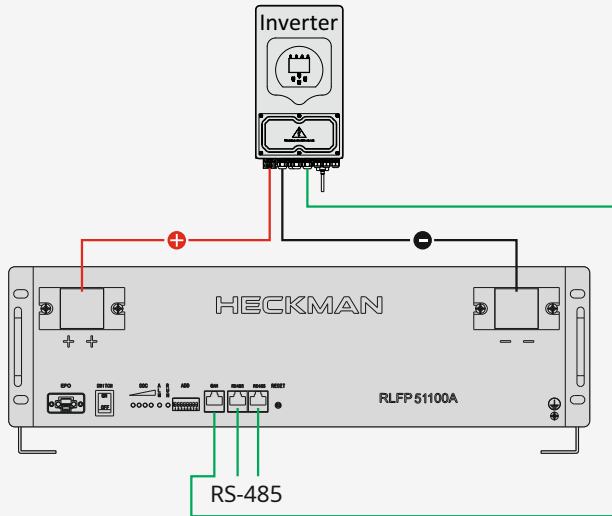

Connection of multiple 51.2 V 300 Ah devices (3 x 100 Ah):

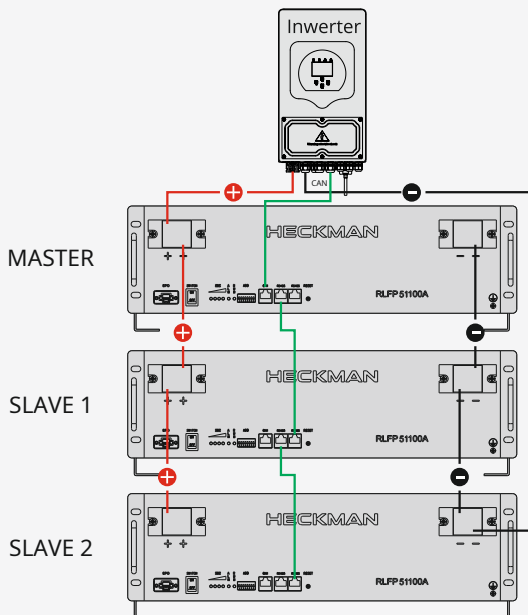

## List of compatible inverters

No.	The manufacturer's name	Inverter model	Mobile interface
1	SMA	SUNNY ISLAND 6.0H-13	CAN
2	Studer	XTM 4000-48	CAN
3	Ginlong	RHI-5K-48ES-5G	CAN
4	Axpert-KING	Axpert-KING 3KW Rack	485
5	SRNE	HF4850S80-145	485
6	Goodwe	GW3648D-ES	CAN
7	Victron	48-3000-35	CAN
8	Zophar	HYD 3000-ES	CAN
9	DEYE	SUN-3.6K-SG03LP1-EU	CAN
10	Growatt	SPF 3500 ES	485/CAN
11	Afore	AF5K-SL	CAN
12	Mager	R5KL1	CAN
13	TOPRAY	CK8.0S	CAN
14	Ginlong	Solis_RAI-3K_ENX_V01	CAN
15	MUST	Ph18.2-5.5KW	CAN
16	Eliosolar	VM III	485
17	Pengcheng	SNA5000 WPV	CAN

## 4. Product use

### 4.1 Detailed product manual

1. After completing the product installation, turn on the switch [*switch(4)*] on the front panel and the product will enter standby mode. The operation LED lights up and the indicator shows the remaining capacity of electricity.
2. While the product is charging, the operation light illuminates and the capacity indicator flashes to indicate the current battery level. When the battery is fully charged, the capacity LED lights up continuously and the battery enters standby mode.
3. When the product is operating in discharge mode, thanks to the inverter, you can use the battery power source for home appliances. The operation LED is on and the capacity indicator shows the current battery level. When the battery is discharged to the final voltage, the output will automatically turn off and the battery will enter standby mode.

## 4.2 Product sleep and wake-up functions

No.	Battery sleep conditions	Battery wake-up conditions
1	no activity (no charging, discharging or communication) for 48 hours, after which the battery goes to sleep	external power supply (voltage 36 V ~ 56.4 V), battery charging, button <i>reset</i>
2	the voltage of individual cells will drop below value set for over-discharge protection (adjustable), or the total voltage drops below the value set for over-discharge protection (adjustable), the battery goes to sleep after 10 minutes	external power supply (voltage 36 V ~ 56.4 V), battery charging, button <i>reset</i>
3	the battery can be put to sleep on request using control (e.g. using a computer)	external power supply (voltage 36V~56.4V), battery charging, button <i>reset</i>

## 5. The most common faults and ways to remove them

No.	Symptoms	Reasons	Solution
1	no exit after switching on	electrical battery voltage is low, the protection against excessive discharge	charge the battery
2	signaling diode does not light up when turned on	BMS (battery system management) is dormant	press the button <i>reset</i>
3	display low level battery charge	too low charging voltage	adjust the charging voltage and inverter voltage to the required parameters
4	short power time	the battery is not fully charged	check charging parameters inverter, such as charging voltage and charging current
5	unstable voltage output when turned on	BMS (system management energy) disturbed	press the button <i>reset</i>
6	communication failure RS-485/CAN	line problem communication or address	check the switch address settings, ports and connections

## 6. List of items in the package

No.	Name	Quantity
1	main module	1 piece.
2	communication cable	1 piece.
3	EPO bridge	1 piece.
4	M6*14 octagonal external screws	8 pcs.
5	mounting rails, rack guides	2 pcs.
6	certificate of conformity	1 piece.

## CE Declaration of Conformity 01/2



<b>Producer</b>	Heckman Sp. z o. o street Columba 43/47, 02-288 Warszawa
<b>Product</b>	Energy storage
<b>Type</b>	RLFP51100A, WLP51100A

Declares that the products listed above are compliant with:

**Directive 2014/30/EU**–Immunity to interference "Electromagnetic Compatibility Directive"

**EN 61000-6-3:2007/A1:2011/AC:2012**

**EN 61000-3-2:2014**

**EN 61000-3-3:2013**

**EN 61000-6-1:2007**

Therefore, the above-mentioned products are marked with the CE symbol.

Warsaw, 14/02/2023

.....  
(places and date of issue)

Chairman of the Board  
**Dominik Dakowicz**

.....  
(name, surname and signature of the authorized person)

# Warranty for Heckman RLFP51100A / WLFP51100A battery energy storage system

This limited warranty ("warranty") applies to lithium iron batteries.

- phosphate products from Heckman and equipment elements (hereinafter referred to as "products") supplied by Heckman Sp. z o. o. (hereinafter referred to as "Heckman" or "seller") to the end user (hereinafter referred to as "purchaser") through an authorized reseller.

## 1. Purpose

The primary purpose of this warranty is to clearly define issues related to the product warranty policy.

## 2. Warranty terms

### 2.1 Warranty period

The warranty period is 120 months, provided that the product is registered on the manufacturer's website, heckman.pl, and provided that annual inspections are performed every 12 months from the date of purchase by an authorized HECKMAN installer. Reports of inspections should be made via the website heckman.pl. Failure to comply with the above conditions limits the warranty to 24 months from the date of purchase.

### 2.2 Limitation of Warranty Coverage

Heckman's liability under this warranty is limited to replacement, repair, reimbursement of costs and compensation. Replaced or repaired products are warranted for the remainder of the original performance warranty period. In no event shall product replacement or repair justify renewal of the performance warranty.

### 2.3 Disclaimer of Warranty

Damage to products resulting from any of the following activities is not covered by this limited warranty:

- incorrect transport, storage, installation or use of inappropriate cables by the purchaser;
- modifications, changes, disassembly, repair or replacement performed by a person other than an employee authorized by Heckman;
- failure to comply with the official installation instructions;
- external factors, including unusual physical or electrical loads (voltage surges, surge, lightning, flood, fire, accidental damage, etc.);
- use of an incompatible inverter, rectifier or part;
- lack of confirmation of installation/acceptance or confirmation of periodic inspection by an authorized Heckman installer.

## 2.4 Warranty Claim

To avoid additional problems with the products, the purchaser should contact the installer directly with any warranty claims.

Information: the products are not protected against spontaneous discharge in the off mode.

## 3. Performance Guarantee (Standard)

Heckman warrants and represents that the product will retain at least 60% of its rated energy for a period of 10 years from the date of initial installation or the minimum energy efficiency in accordance with the table below (whichever comes first) while the battery system is in service under conditions of normal use in accordance with the specifications and instructions provided by Heckman.

The term "nominal capacity" in this document means the initial capacity of the products. Information about this can be found on the product label. To be eligible for a valid 10-year performance warranty, the following requirements must be met:

Nazwa produktu	Energia nominalna	Wydajność energetyczna
RLFP51100A	4,86 kWh	14,6 MWh
WLFP51100A	4,86 kWh	14,6 MWh

### Performance measurement status:

- ambient temperature: 25~30°C;
- BMS system initial battery temperature: 25~30°C.

### Charging/discharging method:

- loading: (0.2)CC/CV;
- discharge: (0.2)CC/CV;
- current: (0.2)C: (20)A;
- measurement of voltage and current on the DC side of the battery.

## 4. Installation and periodic inspections

The condition for the warranty to be accepted is installation/acceptance and periodic inspections in periods no longer than 12 months by an authorized Heckman installer, confirmed by entries in the inspection card. Failure to perform a periodic inspection is the basis for refusing to recognize the warranty.

## 5. Non-warranty policy

For the repair of damage that was not caused by the seller, Heckman provides a paid service, which includes all costs, such as: the cost of materials, labor, storage, transport, customs duties, examination and testing, margin, disposal (if necessary).

## 6. Service products/parts

Service products/parts whose performance is equal to or greater than the performance of the defective products and guaranteed by Heckman may be used as new or refurbished.

In the event that the Products are no longer commercially available, Heckman, at its sole discretion, may replace the Products with other products with the same functions and features or refund the remaining annually amortized value of the purchase price of the Products during the Performance Warranty Period as described in the Compensation Plan below. The purchase price referred to is the list price actually paid by the purchaser.

### Compensation plan

CLASS I: 100% of the purchase price from the date of first installation until the 24th month; CLASS

II: 72% of the purchase price from the 25th to the 36th month;

CLASS III: 58% of the purchase price from the 37th to the 48th month; CLASS

IV: 44% of the purchase price from the 49th to the 60th month; CLASS V: 30%

of the purchase price from the 61st to the 72nd month; CLASS VI: 16% of the

purchase price from the 73rd to the 84th month; CLASS VII: 6% of the

purchase price from the 85th to the 96th month; CLASS VIII: 4% of the

purchase price from the 97th to the 108th month; CLASS IX: 2% of the

purchase price from the 109th to the 120th month;

From month 121, no performance guarantee will be provided.

## 7. Payment Claims Policy

Claims under this warranty must be made to the authorized dealer, from whom you purchased the product. For a warranty claim to be considered, it must include the following information:

1. Original proof of purchase;
2. Description of the suspected fault(s) prepared by the authorized service center;
3. The corresponding product serial number and date of first installation.

Buyers who are unable to contact an authorized reseller

from whom they purchased the product, please contact Heckman using the "Service Request" form located on the Heckm website: [www.heckman.pl](http://www.heckman.pl).

## 8. Countries Covered

This warranty applies only in the countries listed below, and Heckman shall not be liable for claims under this warranty brought or arising in countries other than those listed in this warranty.

- Poland.

## Inspection card

Installation site address:

Heckman serial number: Inverter

(make/model/serial number):

Installation date:

Date and signature of the authorized person

Authorized installer's stamp

12 months review:  Date, signature and stamp of the authorized installer	24 month review:  Date, signature and stamp of the authorized installer
36 month overview:  Date, signature and stamp of the authorized installer	48 month review:  Date, signature and stamp of the authorized installer
60 month review:  Date, signature and stamp of the authorized installer	72 month review:  Date, signature and stamp of the authorized installer
84 month review:  Date, signature and stamp of the authorized installer	96 month overview:  Date, signature and stamp of the authorized installer
108 month review:  Date, signature and stamp of the authorized installer	Additional notes:  Date, signature and stamp of the authorized installer

## Service notes

## Service notes

## Service notes

## Service notes

## **Service notes**

## Service notes

**HECKMAN**

TECHNOLOGY serves MAN

# HECKMAN

TECHNOLOGY serves MAN

**HECKMAN Sp. z o. o**

street Columba 43/47, 02-288 Warszawa

NIP: 9522156846 | KRS: 0000658690 | REGON: 366361579

+ 48 22 100 59 60 | kontakt@heckman.pl